



U-GAGE™ T30 Series with Dual Discrete Outputs

Ultrasonic Sensors with TEACH-Mode Programming

Dual-Discrete U-GAGE T30 Series Features



- Fast, easy-to-use TEACH-mode programming; no potentiometer adjustments
- Choose to set a specific window size and position, or a set point centered within its own 10-mm window, for either or both outputs
- Program both outputs together or independently. The two outputs may be identical, independent, overlapping, or complementary.
- Remote TEACH input for security and convenience
- Choose models with 150 mm to 1 m range (5.9" to 39.4") or 300 mm to 2 m range (11.8" to 78.7")
- Wide operating temperature range of -20° to +70°C (-13° to +158°F)
- Choose models with either NPN or PNP dual discrete outputs
- LED indicators for Power ON/OFF; Signal Strength; and Discrete Outputs Conducting
- Choose 2 m (6.5') or 9 m (30') integral unterminated cable or 5-pin Euro-style QD connector
- Compact, self-contained sensor package
- Rugged design for use in demanding sensing environments; rated IEC IP67, NEMA 6P

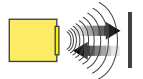
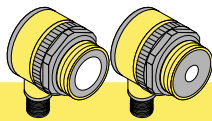

Ultrasonic, 228 or 128 kHz

Dual-Discrete U-GAGE T30 Series Models

Models	Range and Frequency	Cable*	Supply Voltage	Discrete Output	Response Time
T30UDNA T30UDNAQ	150 mm to 1 m (5.9" to 39")	2 m (6.5') 5-pin Euro QD	12 to 24V dc	NPN (sinking)	50 milliseconds
T30UDPA T30UDPAQ	228 kHz	2 m (6.5') 5-pin Euro QD		PNP (sourcing)	
T30UDNB T30UDNBQ	300 mm to 2 m (11.8" to 79")	2 m (6.5') 5-pin Euro QD		NPN (sinking)	100 milliseconds
T30UDPB T30UDPBQ	128 kHz	2 m (6.5') 5-pin Euro QD		PNP (sourcing)	

* NOTE: 9 m (30') cables are available by adding suffix "W/30" to the model number of any cabled sensor (e.g., T30UDNA W/30)

U-GAGE™ T30 Series with Dual Discrete Outputs

Dual-Discrete U-GAGE T30 Series Overview

The U-GAGE is an easy-to-use ultrasonic sensor, ideal for demanding environments. Simple push-button programming provides flexibility for a variety of applications. Excellent for gauging applications such as sensing of liquid levels in a tank or for sensing most clear materials.

Each sensor includes two discrete outputs, which may be programmed independently with different window limits or together with identical limits. Each output has the option of being set with a sensing distance set point centered within a 10-mm window.

Dual-Discrete U-GAGE T30 Series Programming

Window limits may be taught to the sensor in several ways. The following methods describe the programming procedures using the push buttons on the back of the sensor; remote programming (remote TEACH) procedures are described on page 4.

NOTE: When the sensor changes state between PROGRAM and RUN modes, all of the LED indicators turn OFF momentarily, before the appropriate LEDs come ON as described below. The sensing window limits expand temporarily to full scale (max range) during PROGRAM mode.

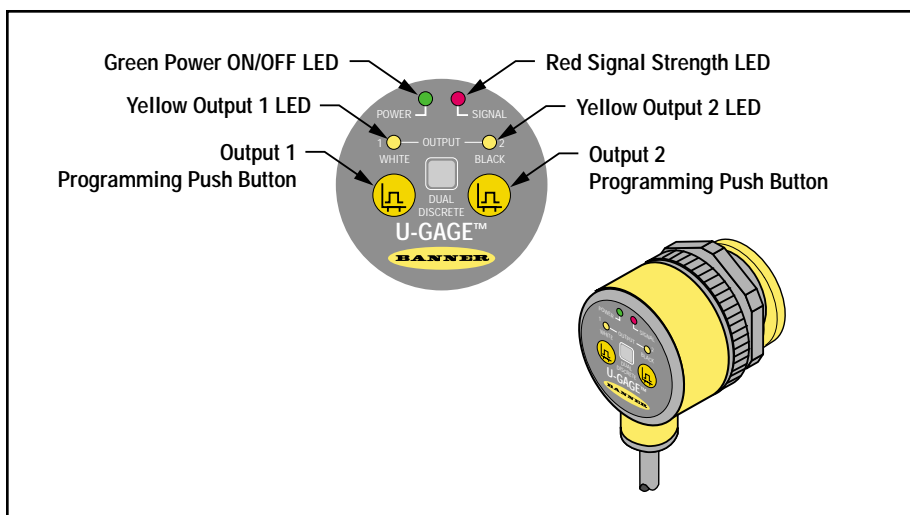

Figure 1. U-GAGE T30 Series sensor programming push buttons and indicators

Program the outputs independently to define separate sensing windows (both their size and placement) or program the outputs simultaneously for complementary or fixed-field operation.

Sensing windows may be as large as 0.85 m for 1-m range models, and as large as 1.7 m for 2-m range models. Use the procedures as described, or combine them for specialized applications.

NOTE: Output 1 = White wire
Output 2 = Black wire

U-GAGE™ T30 Series with Dual Discrete Outputs

General Notes on Programming:

1. The sensor will return to RUN mode if the first TEACH condition is not registered within 120 seconds.
2. After the first limit is taught, the sensor will remain in PROGRAM mode until the TEACH sequence is finished.
3. Press and hold the programming push button > 2 seconds (before teaching the second limit) to exit PROGRAM mode without saving any changes. The sensor will revert to the last saved program.
4. The sensor allows for some forgiveness in the teaching of a set point. If both near and far limits are not exactly the same (but are closer than the minimum 10-mm required to define a window), the sensor will set a 10-mm window with the center at the "average" of the two limits.

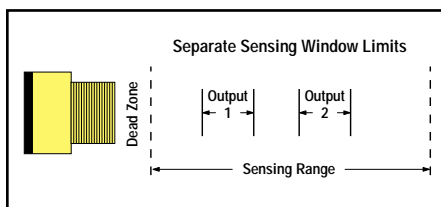

Figure 2a. Programming separate sensing window limits

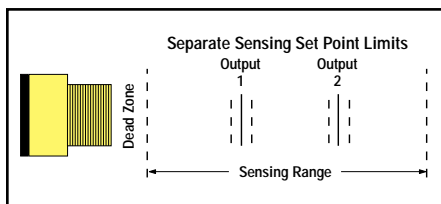

Figure 2b. Programming separate sensing set point limits

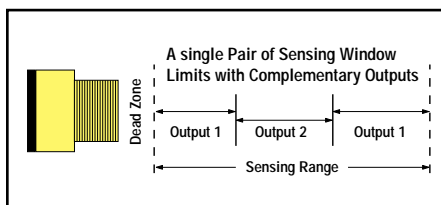

Figure 2c. Programming a single pair of sensing window limits, complementary outputs

To Program Separate Sensing Window Limits

Each output conducts when the target is inside that output's window limits. The two sets of window limits may overlap or be completely independent. See Figure 2a.

1. Press and hold the push button for the selected output until the green Power LED goes OFF and the yellow LED for the programmed output comes ON.
2. Position the target at the first limit and click the push button. The yellow Output LED flashes.
3. Position the target at the second limit and click the push button. The green Power LED comes ON. The sensor is in RUN mode.
4. Repeat the procedure for the second output, if desired.

To Program Separate Sensing Set Point Limits

Each output conducts when the target is inside that output's 10-mm limits (centered on the taught set point, or the average of the two limits). The window limits for the two outputs may overlap or be completely independent. See Figure 2b.

1. Press and hold the push button for the selected output until the green Power LED goes OFF and the yellow LED for the programmed output comes ON.
2. Position the target at the set point and click the push button. The yellow Output LED flashes.
3. While the target remains at the first limit (or within 10 mm), click the push button once more. The green Power LED comes ON. The sensor is in RUN mode.
4. Repeat the procedure for the second output, if desired.

To Program A Single Pair of Sensing Window Limits, with Complementary Outputs

Output 2 conducts when inside the programmed window limits; Output 1 conducts for all other conditions. See Figure 2c.

1. Press and hold both push buttons (or press and hold one and then the other) until the green Power LED goes OFF and both yellow Output LEDs come ON.
2. Position the target at the first limit and click a push button. The yellow Output LED flashes.
3. Position the target at the second limit and click a push button. The green Power LED comes ON. The sensor is in RUN mode.

NOTE: The window limits must be ≥ 10 mm or the sensor will default to fixed-field style.

U-GAGE™ T30 Series with Dual Discrete Outputs

To Program A Single Sensing Set Point, with Complementary Outputs (Fixed-Field Style)

Output 2 conducts when inside the programmed set point; Output 1 conducts outside (away) from this point. See Figure 2d.

1. Press and hold both push buttons (or press and hold one and then the other) until the green Power LED goes OFF and both yellow Output LEDs come ON.
2. Position the target at the first limit and click a push button. The yellow Output LED flashes.
3. While the target remains at the first limit (or within 10 mm), click the push button once more. The green Power LED comes ON. The sensor is in RUN mode.

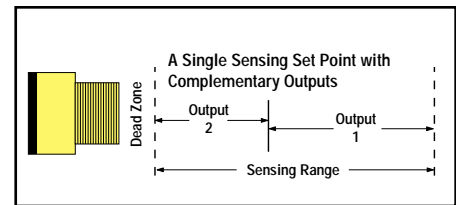

Figure 2d. Programming separate sensing set point limits, complementary outputs

Remote Programming

To program the sensor remotely or to disable the keypad, the Remote Programming function may be used. Disabling the keypad prevents anyone on the production floor from adjusting any of the programming settings. Connect the gray wire of the sensor to +12 to 24V dc, with a remote programming switch connected between them. NOTE: The impedance of the remote teach input is 55 kΩ.

Programming is accomplished by following the sequence of input pulses. The duration of each pulse (corresponding to a push button "click"), and the period between multiple pulses, are defined as: $0.04 \text{ seconds} < T < 0.8 \text{ seconds}$.

- 1 pulse: Programs first Output 1 limit. Wait $> 0.8 \text{ sec}$. Next pulse programs second Output 1 limit.
- 2 pulses: Programs first Output 2 limit. Wait $> 0.8 \text{ sec}$. Next pulse programs second Output 2 limit.
- 3 pulses: Programs both outputs together (complementary or fixed-field mode). First 3-pulse programs the first limit; wait $> 0.8 \text{ sec}$. Next pulse programs second limit and determines output configuration.
- 4 pulses: Disables (locks out) or enables the keypad for security.

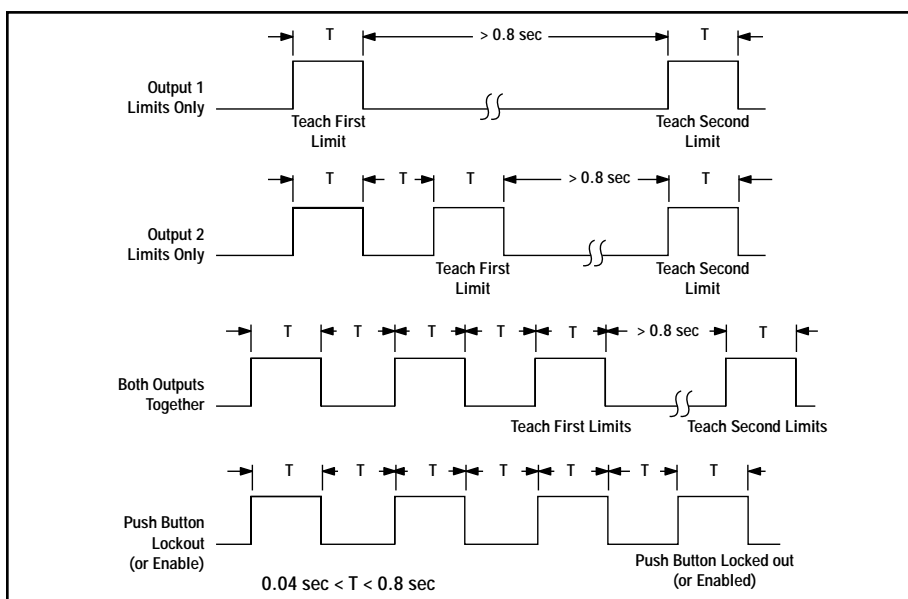

Figure 3. Timing programs for remote TEACH programming

NOTE: Hold the Remote line high > 2 seconds (before teaching the second limit) to exit PROGRAM mode without saving any changes. The sensor will revert to the last saved program.

U-GAGE™ T30 Series with Dual Discrete Outputs

RUN Mode

NOTE: All LED indicators momentarily go OFF when sensor changes state between PROGRAM and RUN modes.

Signal LED

The red Signal LED indicates the strength and condition of the sensor's incoming signal.

Signal LED Status	Indicates
OFF	No signal is received, or the target is beyond the range limitations of the sensor (with some tolerance beyond the recommended minimum and maximum sensing distance)
Flashing	Relative received signal strength; the faster the LED flashes, the stronger the signal

Output LEDs

Each yellow Output LED lights when a target is sensed within the programmed window limits.

Power ON/OFF LED

The green Power ON/OFF LED indicates the operating status of the sensor.

Power ON/OFF LED	Indicates
OFF	Power is OFF (or in PROGRAM mode, if other LEDs are ON)
ON Solid	Sensor is operating normally (power is ON, RUN mode)
Flashing	Discrete output is overloaded (RUN mode)

Self-Diagnostic Error Mode

In the unlikely event of a microprocessor memory error, all of the LEDs will flash in sequence. If this occurs, the setup parameters have been lost and the sensor may be corrupt. Contact your Banner representative for further information.

U-GAGE™ T30 Series with Dual Discrete Outputs

U-GAGE T30 Series Specifications

Proximity Mode Range	<p>"A" suffix models: 150 mm (5.9") min. near limit; 1 m (39") max. far limit</p> <p>"B" suffix models: 300 mm (11.8") min. near limit; 2 m (79") max. far limit</p>
Supply Voltage	12 to 24V dc (10% max. ripple) at 90 mA, exclusive of load
Supply Protection Circuitry	Protected against reverse polarity and transient voltages
Output Configurations	SPST solid-state switch conducts when target is sensed within sensing window; choose NPN (current sinking) or PNP (current sourcing) models
Output Ratings	<p>Dual Discrete Outputs: 100 mA maximum, total – both outputs</p> <p>OFF-state leakage current: less than 10 microamps</p> <p>ON-state saturation voltage: less than 1V at 10 mA and less than 1.5V at 100 mA</p>
Output Protection	Protected against continuous overload and short-circuit; transient over-voltage; no false pulse on power-up
Output Response Time	<p>"A" suffix models: 50 milliseconds</p> <p>"B" suffix models: 100 milliseconds</p>
Sensing Performance (Specified using a 10 cm x 10 cm aluminum target at 25°C under fixed sensing conditions.)	<p>Sensing repeatability: ±0.25% of distance</p> <p>Minimum window size: 10 mm (0.4")</p> <p>Hysteresis of discrete output: 2.5 mm (0.10")</p>
Adjustments	Sensing window limits: TEACH-mode programming of near and far window limits may be set using membrane push buttons on sensor or remotely via TEACH input (see pages 2-4). Window limits may be programmed separately, or together.
Indicators	<p>Four status LEDs:</p> <p>In RUN mode:</p> <p>Green ON = Power ON, RUN mode</p> <p> Flashing = Output is overloaded</p> <p>Red Flashing = Relative received signal strength</p> <p>Yellow ON = Output is conducting</p> <p>In Program mode:</p> <p>Green OFF = PROGRAM mode</p> <p>Red Flashing = Relative received signal strength</p> <p>Yellow { ON = Ready for first window limit</p> <p> { Flashing = Ready for second limit</p> <p> { OFF = Not teaching this output</p>
Construction	Molded reinforced thermoplastic polyester housing
Environmental Rating	Leakproof design is rated IEC IP67; NEMA 6P
Connections	2 m (6.5') or 9 m (30') 5-conductor PVC-covered attached cable, or 5-pin Euro-style quick-disconnect fitting (see page 9 for optional quick-disconnect cables)
Operating Conditions	<p>Temperature: -20° to +70° C (-4° to 158° F)</p> <p>Maximum relative humidity: 100%</p>
Vibration and Mechanical Shock	All models meet Mil. Std. 202F requirements. Method 201A (Vibration: 10 to 60Hz max., double amplitude 0.06", maximum acceleration 10G). Also meets IEC 947-5-2 requirements: 30G, 11 ms duration, half sine wave.
Application Notes	Objects passing inside the specified near limit will produce a false response.

U-GAGE™ T30 Series with Dual Discrete Outputs

U-GAGE T30 Series Performance Curves

With Plate Target (Typical)

1-Meter Models

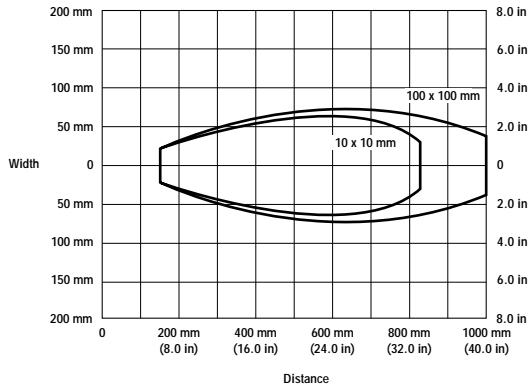

2-Meter Models

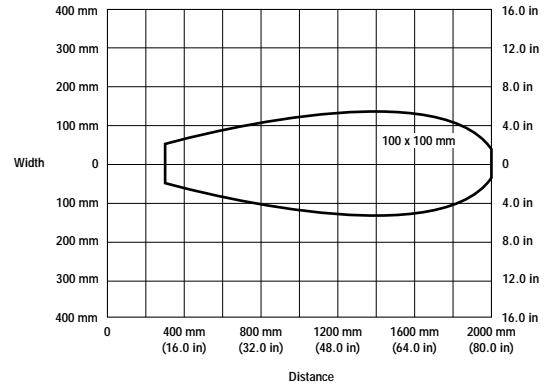

With Rod Target (Typical)

1-Meter Models

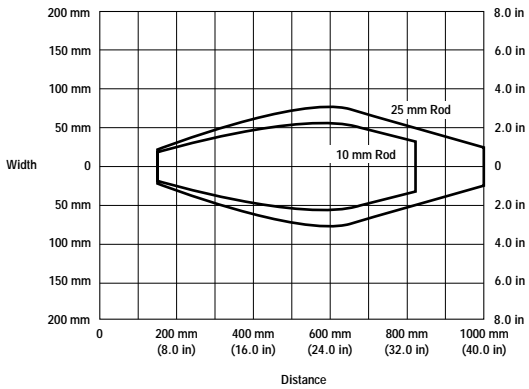

2-Meter Models

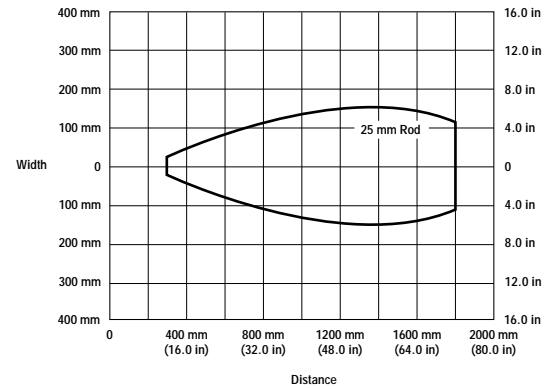

Dual-Discrete U-GAGE T30 Series Dimensions

Cabled Models

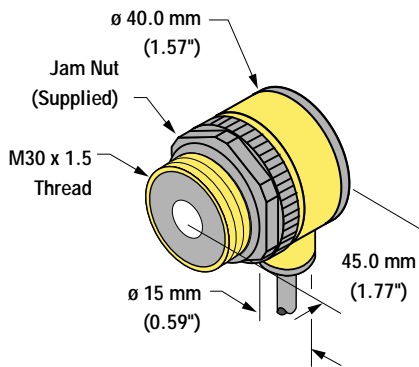

Quick-Disconnect Models

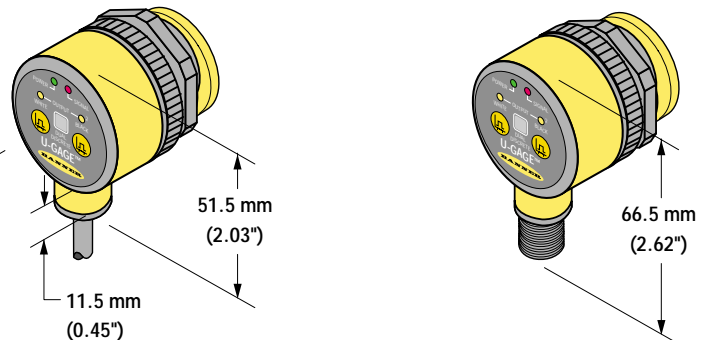

U-GAGE™ T30 Series with Dual Discrete Outputs

Dual-Discrete U-GAGE T30 Series Hookups

Cabled NPN

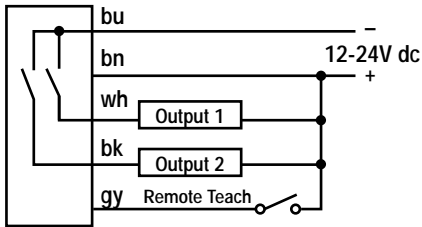

Cabled PNP

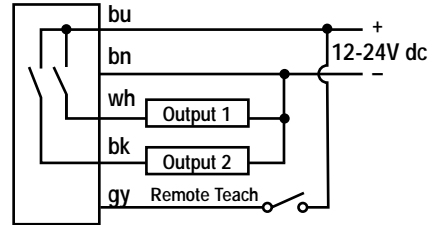

Quick-Disconnect NPN

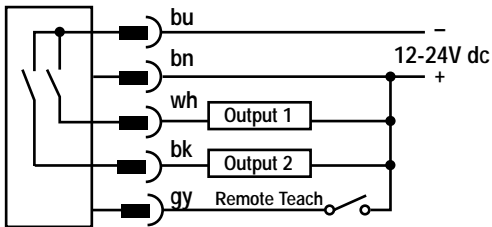

Quick-Disconnect PNP

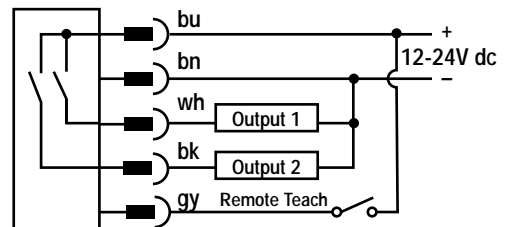

Accessories

Quick-Disconnect (QD) Cables

Style	Model	Length	Connector	Pin-out
5-Pin Euro Straight	MQDC1-506 MQDC1-515 MQDC1-530	2 m (6.5') 5 m (15') 10 m (30')	<p>44 mm max. (1.7") ø 15 mm (0.6") M12 x 1</p>	<p>White Wire Blue Wire Gray Wire Black Wire Brown Wire</p>
5-Pin Euro Right-angle	MQDC1-506RA MQDC1-515RA MQDC1-530RA	2 m (6.5') 5 m (15') 9 m (30')	<p>38 mm max. (1.5") 38 mm max. (1.5") M12 x 1 ø 15 mm (0.6")</p>	

U-GAGE™ T30 Series with Dual Discrete Outputs

Mounting Brackets

SMB30A	<ul style="list-style-type: none"> • Angled-mount bracket • Stainless steel 	SMB1815SF	<ul style="list-style-type: none"> • Compact 30 mm split clamp with swivel, black reinforced thermoplastic polyester • Stainless steel hardware included
<p>* Use 5 mm (#10) screws to mount bracket. Drill screw holes 40.0 mm (1.58\") apart.</p>		<p>The 15 mm diameter hub of the T30 is mounted into the swivel using two set screws.</p>	
SMB30C	<ul style="list-style-type: none"> • 30 mm split clamp, black reinforced thermoplastic polyester • Stainless steel hardware included 	SMB30SC	<ul style="list-style-type: none"> • 30 mm split clamp with swivel, black reinforced thermoplastic polyester • Stainless steel hardware included
<p>Nut Plate M5 x 0.8 x 80 mm Screw (2)</p>			

U-GAGE™ T30 Series with Dual Discrete Outputs

U-GAGE™ T30 Series with Dual Discrete Outputs

U-GAGE™ T30 Series with Dual Discrete Outputs



WARRANTY: Banner Engineering Corp. warrants its products to be free from defects for one year. Banner Engineering Corp. will repair or replace, free of charge, any product of its manufacture found to be defective at the time it is returned to the factory during the warranty period. This warranty does not cover damage or liability for the improper application of Banner products. This warranty is in lieu of any other warranty either expressed or implied.



WARNING . . . Not To Be Used for Personnel Protection

Never use these products as sensing devices for personnel protection. Doing so could lead to serious injury or death.

These sensors do NOT include the self-checking redundant circuitry necessary to allow their use in personnel safety applications. A sensor failure or malfunction can cause either an energized or de-energized sensor output condition. Consult your current Banner Safety Products catalog for safety products which meet OSHA, ANSI and IEC standards for personnel protection.