

## LT3 Long-Range Time-of-Flight Laser Sensor

Self-contained Class 2 laser distance-gauging sensor, analog and discrete outputs



### LT3 Sensor Features

- Extremely long range: 5 m with white targets, or 3 m with gray targets
- Banner's unique scalable analog output automatically distributes the output signal over the width of the programmed sensing window
- Analog and Discrete (switched) outputs in each sensor, with independent window limits†
- Discrete output can be used for precision background suppression
- Choose NPN or PNP discrete output, plus 0 to 10V dc or 4 to 20 mA sourcing analog output
- Fast, easy-to-use integrated push-button TEACH-mode programming; no potentiometer adjustments
- Remote TEACH function for security and convenience
- Output response is programmable for three speeds
- Choose 2 m or 9 m unterminated cable, or 8-pin Euro-style swivel QD connector
- Rugged construction withstands demanding sensing environments; rated IEC IP67, NEMA 6

### LT3 Distance Gauging Sensor Models

Models	Sensing Distance	Cable*	Supply Voltage	Discrete Output	Analog Output
LT3PU	300 to 5000 mm (11.8" to 197") for 90% reflectivity white card (see specifications on page 6 for more information.)	2 m (6.5') 8-wire	12 to 24V dc	PNP (Sourcing)	Analog Voltage (0 to 10V dc)
LT3PUQ		8-pin Euro-style QD			
LT3NU		2 m (6.5') 8-wire		NPN (Sinking)	
LT3NUQ		8-pin Euro-style QD			
LT3PI		2 m (6.5') 8-wire		PNP (Sourcing)	Analog Current (4 to 20 mA)
LT3PIQ		8-pin Euro-style QD			
LT3NI		2 m (6.5') 8-wire		NPN (Sinking)	
LT3NIQ		8-pin Euro-style QD			

\* 9 meter cables are available by adding suffix "W/30" to the model number of any cabled sensor (e.g., **LT3PU W/30**). A model with a QD connector requires a mating cable; see page 8.

†NOTE: See datasheet p/n 68503 for dual-discrete models  
See datasheet p/n 69504 for retroreflective models

# LT3 Long-Range Time-of-Flight Laser Sensor – Analog/Discrete Outputs

## Theory of Operation

A short electrical pulse drives a semiconductor laser diode to emit a pulse of light. The emitted light is collimated through a lens, which produces a very narrow laser beam. The laser beam bounces off the target, scattering some of its light through the sensor's receiving lens to a photodiode, which creates an electrical pulse. The time interval between the two electrical pulses (transmitting and receiving the beam) is used to calculate the distance to the target, using the speed of light as a constant.

Multiple pulses are evaluated by the sensor's microprocessor, which calculates the appropriate output value. The analog output provides a variable signal (4 to 20 mA or 0 to 10V dc, depending on model) that is proportional to the target's position within the user-programmed analog window limits. The discrete (switched) output energizes whenever the target is located between the user-programmed discrete window limits. Window limits for the analog and discrete outputs may be the same, or they may be programmed independently.

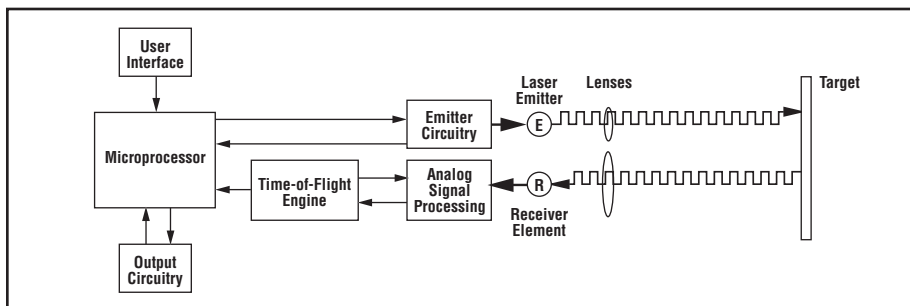

Figure 1. Theory of operation

## L-GAGE LT3 Sensor Programming

### Response Speed

Prior to setting window limits, use the sensor's Speed push button to toggle between the three response speed settings. The selected speed will be indicated by one of the three Response Speed indicator LEDs (see Figure 2). See Specifications for further information.

### Sensor Setup

Allow 20 minutes after power-up to allow the sensor's internal temperature to stabilize, before operating or attempting to program the sensor. If the sensor will be used in applications where the temperature is several degrees higher or lower than ambient, allow the sensor to stabilize in that condition before programming the window limits. (Range will decrease as the sensor warms up.)

The laser enable feature allows the sensor to be continually powered, and enabled only when being used. This eliminates the need for the extended warm-up period between uses.

The sensor's red Signal LED indicates the condition of the received signal from the object being measured. When programming window limits, this LED must be ON solid (not flashing) for the sensor to accept the setting. To ensure that the received signal will not be marginal during operation, move the target object 30 cm beyond the furthest desired set point during setup, and verify that the signal LED is still ON solid.

### Window Limits

Window limits may be taught to the sensor in several ways. The following methods describe the programming procedures using the push buttons on the top of the sensor; remote programming (remote TEACH) procedures are described on page 4.

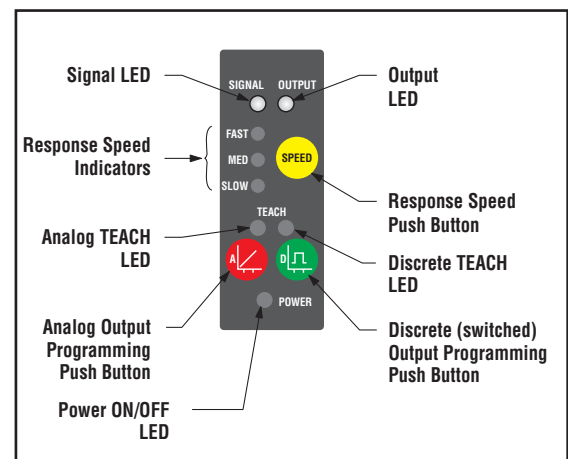

Figure 2. LT3 Time-of-Flight Sensor features

# LT3 Long-Range Time-of-Flight Laser Sensor – Analog/Discrete Outputs

## Class 2 Safety Notes

Low-power lasers are by definition incapable of causing eye injury within the duration of the blink, or aversion response, of 0.25 seconds. They must also emit only visible wavelengths (400-700 nm). Therefore, an eye hazard can exist only if an individual overcomes the natural aversion to bright light and stares directly into the laser beam. These lasers are required to have a “hazard” label and to have an indicator light to indicate that laser emission is occurring.

### When operating a Class 2 laser:

- Do not permit a person to stare directly into the beam
- Do not point the laser at a person’s eye at close range

### Beam Paths:

The beam emitted by a class 2 laser product should be terminated at the end of its useful path. Open laser beam paths should be located above or below eye level, where practical.

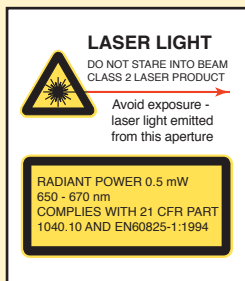

### Teaching Limits for Either Analog or Discrete Output

1. Choose the output for the first set of window limits (analog or discrete) and push and hold the corresponding button until the appropriate TEACH LED turns ON (solid). This indicates the sensor is waiting for the first limit.
2. Position the target for the first limit and briefly “click” the same button. This will teach the sensor the first limit. The TEACH LED will flash to acknowledge receiving the first window limit; it is now waiting for the second limit.
3. Position the target for the second limit and “click” the button again. This will teach the sensor the second limit. The TEACH LED turns OFF; the sensor is now in normal RUN mode.
4. Repeat for the other output (analog or discrete) if a second output is desired.

NOTE: Press and hold the same button > 2 seconds (before teaching the second limit) to exit PROGRAM mode without saving any changes. The sensor will revert to the last saved program.

### Teaching Analog Limits Using the Auto-Zero Feature

For some applications, a sensing distance set point centered within a fixed sensing window may be required. The TEACH procedure for this application is simple: teaching the same limit twice causes the sensor to program a 1 m window centered on the position taught (position  $\pm 0.5$  m).

### Teaching Discrete Limits for Background Suppressor

For some applications, ignoring objects beyond a certain distance may be required. To suppress the background, place a target object at the selected distance, and teach the position twice. The sensor’s discrete output will activate when an object is detected between the sensor’s minimum sensing distance and the taught position.

NOTE: The sensor allows for some forgiveness in this procedure. If the two limits are not exactly the same (but less than 20 mm apart), the sensor will put the set point at the “average” of the two limits.

### Teaching Identical Limits for Both Analog and Discrete Outputs Simultaneously

To set both the analog and the discrete outputs at exactly the same limits, both may be set simultaneously.

1. Push and hold either the Analog or the Discrete programming push button until the appropriate TEACH LED turns ON. “Click” the other push button, its TEACH LED turns ON. The sensor is waiting for the first limit.
2. Position the target for the first limit and “click” either programming push button. Both TEACH LEDs will flash to acknowledge receiving the first window limit; the sensor is now waiting for the second limit.
3. Position the target for the second limit and “click” either button again to teach the sensor the second limit.
4. Both TEACH LEDs will turn OFF and the sensor will return to RUN mode.

### General Notes on Programming:

1. The sensor will return to RUN mode if the first TEACH condition is not registered within 120 seconds.
2. After the first limit is taught, the sensor will remain in PROGRAM mode until the TEACH sequence is finished.
3. Press and hold the programming push button > 2 seconds (before teaching the second limit) to exit PROGRAM mode without saving any changes. The sensor will revert to the last saved program.

# LT3 Long-Range Time-of-Flight Laser Sensor – Analog/Discrete Outputs

## Remote Programming

To program the sensor remotely or to disable the keypad, the Remote Programming function may be used. Disabling the keypad prevents anyone on the production floor from adjusting any of the programming settings. Connect the yellow wire of the sensor to +12 to 24V dc, with a remote programming switch connected between them. NOTE: The impedance of the remote teach input is 55 kΩ.

Programming is accomplished by following the sequence of input pulses. The duration of each pulse (corresponding to a push button “click”), and the period between multiple pulses, are defined as “T”: 0.04 seconds < T < 0.8 seconds.

- 1 pulse: Programs first discrete limit. Wait > 0.8 sec. Next pulse programs second discrete limit.
- 2 pulses: Programs first analog limit. Wait > 0.8 sec. Next pulse programs second analog limit.
- 3 pulses: Programs first analog and discrete limit. Wait > 0.8 sec. Next pulse programs second analog and discrete limits.
- 4 pulses: Disables (locks out) or enables the keypad for security.

NOTE: Hold the Remote line high > 2 seconds (before teaching the second limit) to exit PROGRAM mode without saving any changes. The sensor will revert to the last saved program.

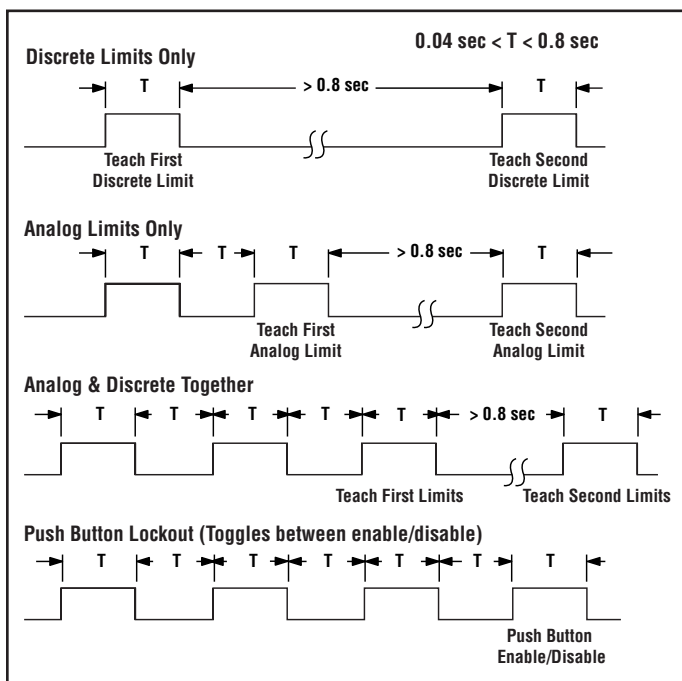

Figure 3. Timing programs for remote TEACH procedures

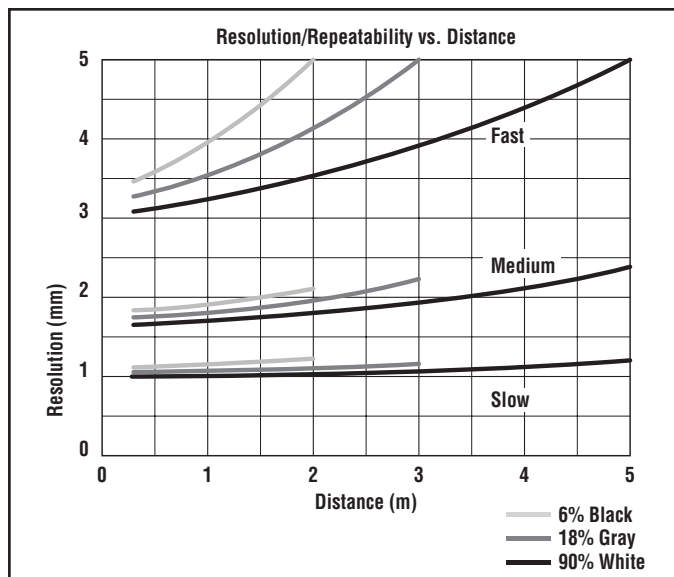

Figure 4. LT3 resolution

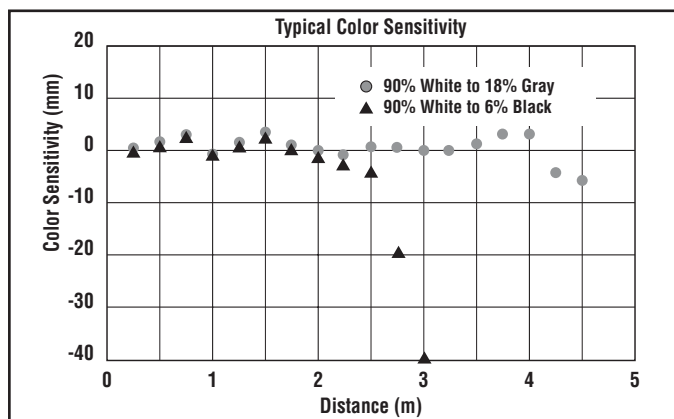

Figure 5. LT3 color sensitivity (typical)

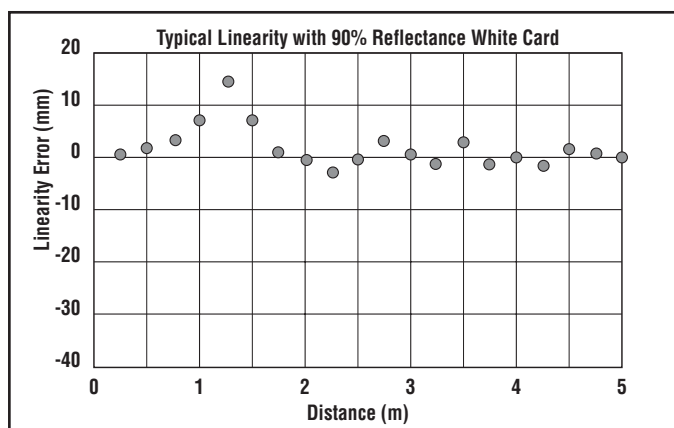

Figure 6. LT3 linearity (typical)

# LT3 Long-Range Time-of-Flight Laser Sensor – Analog/Discrete Outputs

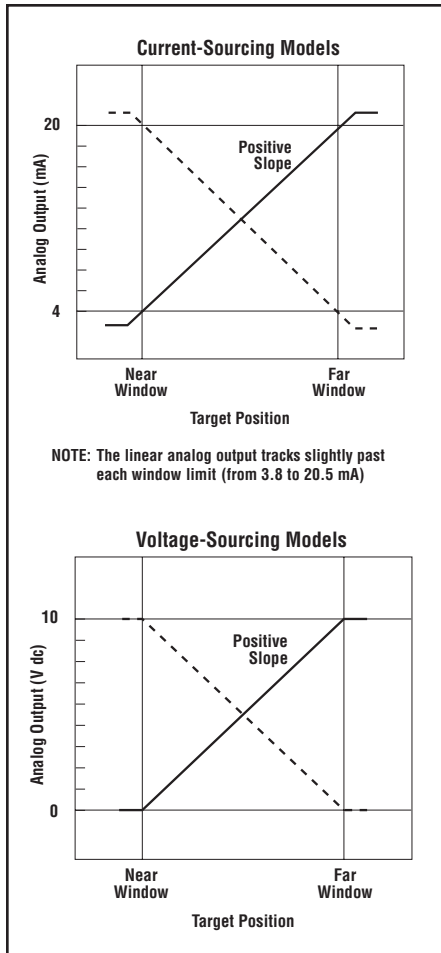

Figure 7. Output as a function of target position

## RUN Mode

### Signal LED

The red Signal LED indicates the strength and condition of the sensor's incoming signal.

Signal LED Status	Indicates
ON	Good signal
OFF	No signal is received, or the target is beyond the range limitations of the sensor (with some tolerance beyond the recommended minimum and maximum sensing distance)
Flashing	Marginal signal strength (can not teach limits)

### Output LED

The yellow Output LED lights when a target is sensed within the programmed discrete window limits.

### Power ON/OFF LED

The green Power ON/OFF LED indicates the operating status of the sensor.

Power ON/OFF LED	Indicates
OFF	Power is OFF
Flashing @ 2Hz	Discrete output is overloaded (RUN mode)
Flashing @ 1Hz	Power is ON, Laser is disabled
ON Solid	Sensor is operating normally (power is ON, Laser enabled)

### Power Up/Laser Enable

When powering up the sensor, the following should occur:

- All LEDs turn ON for 1 second
- Allow 0.6 second delay for Laser Enable at power up. (If sensor is already powered up, allow 0.1 second for Laser Enable.)

## Analog Output

The L-GAGE LT3 sensor may be programmed for either a positive or a negative output slope, based on which condition is taught first (see Figure 7). If the near limit is taught first, the slope will be positive; if the far limit is taught first, the slope will be negative. Banner's scalable analog output automatically distributes the output signal over the width of the programmed sensing window.

# LT3 Long-Range Time-of-Flight Laser Sensor – Analog/Discrete Outputs

## Specifications

<b>Sensing Range</b>	<b>90% White card:</b> 0.3 to 5 m	<b>18% Gray card:</b> 0.3 to 3 m	<b>6% Black card:</b> 0.3 to 2 m
<b>Supply Voltage and Current</b>	12 to 24V dc (10% maximum ripple); 108 mA max. @24V dc or [2600/V dc] mA		
<b>Supply Protection Circuitry</b>	Protected against reverse polarity and transient voltages		
<b>Delay at Power-up</b>	1 second; outputs do not conduct during this time		
<b>Sensing Beam</b>	658 nm visible red IEC and CDRH Class 2 laser; 0.5 mW max. radiant output power; typical beam dia: 6 mm (typical laser lifetime 75,000 hours)		
<b>Output Protection</b>	Protected against short circuit conditions		
<b>Output Configuration</b>	<b>Discrete (switched):</b> SPST solid-state switch; choose NPN (current sinking) or PNP (current sourcing) models <b>Analog output:</b> 0 to 10V dc or 4 to 20 mA		
<b>Output Rating</b>	<b>Discrete (switched) output:</b> 100 mA maximum <b>Off-state leakage current:</b> < 5µA <b>Output saturation NPN:</b> < 200 mV @ 10 mA and < 600 mV @100 mA <b>Output saturation PNP:</b> < 1.2V at 10 mA; < 1.6V at 100 mA <b>Analog voltage output:</b> 2.5 kΩ minimum load impedance <b>Analog current output:</b> 1kΩ max. @24V; max. load resistance = $[V_{CC}-4.5/0.02 \Omega]$		
<b>Output Response Time</b>	<b>Discrete output</b> <b>Fast:</b> 1 ms ON and OFF <b>Medium:</b> 10 ms ON and OFF <b>Slow:</b> 100 ms ON and OFF	<b>Analog Voltage output (-3 dB)</b> <b>Fast:</b> 1000 Hz (1 ms average/1 ms update rate) <b>Medium:</b> 100 Hz (10 ms average/2 ms update rate) <b>Slow:</b> 10 Hz (100 ms average/4 ms update rate)	
<b>Linearity</b>	± 3 cm from 0.3 to 1.5 m; ± 2 cm from 1.5 to 5 m. See Figure 6. (Specified @24V dc, 22° C using a 90% reflectance white card)		
<b>Resolution/Repeatability</b>	See Figure 4.		
<b>Color Sensitivity</b>	90% white to 18% gray: <10 mm; 90% white to 6% black: < 20 mm. See Figure 5.		
<b>Discrete Output Hysteresis</b>	<b>Fast:</b> 10 mm <b>Medium:</b> 5 mm <b>Slow:</b> 3 mm		
<b>Temperature Drift</b>	< 2mm / °C		
<b>Minimum Window Size</b>	100 mm		
<b>Remote Teach Input</b>	18 kΩ minimum (65 kΩ at 5V dc)		
<b>Remote TEACH</b>	<b>To teach:</b> Connect yellow wire to +5 to 24V dc <b>To disable:</b> Connect yellow wire to 0 to +2V dc (or open connection) See Remote Programming on page 4.		
<b>Adjustments</b>	<b>Response speed:</b> Push button toggles between 1, 10 and 100 ms <b>Window limits (analog or discrete):</b> TEACH-mode programming of near and far window limits (see programming procedure). Limits may also be taught remotely via TEACH input (see page 4). <b>Analog output slope:</b> The first limit taught is assigned to minimum output current or voltage (4 mA or 0V dc)		
<b>Laser Control</b>	Connect red wire to +5 to 24V dc to enable laser beam; connect to 0 to +1.8V dc (or open connection) to disable; 100 millisecond delay upon enable, when sensor is powered.		
<b>Indicators</b>	<b>Green Power ON LED:</b> Indicates when power is ON, overloaded output and laser status <b>Yellow Output LED:</b> Indicates when discrete load output is conducting <b>Red Signal LED:</b> Indicates target is within sensing range and the condition of the received light signal <b>Yellow Speed LED:</b> Indicates the response speed setting <b>Red/Green TEACH LEDs:</b> Sensor is in programming mode (red – analog output; green – discrete output) NOTE: See page 5 for more information on indicator behavior.		

# LT3 Long-Range Time-of-Flight Laser Sensor – Analog/Discrete Outputs

## Specifications, cont'd

<b>Construction</b>	<b>Housing:</b> ABS/polycarbonate blend <b>Window:</b> Acrylic <b>Quick-disconnect:</b> ABS/polycarbonate blend
<b>Environmental Rating</b>	IP67, NEMA 6
<b>Connections</b>	2 m (6.5') or 9 m (30') shielded 7-conductor (with drain) PVC-jacketed attached cable or 8-pin Euro-style quick-disconnect
<b>Operating Conditions</b>	<b>Temperature:</b> 0° to +50°C (+32° to +122°F) <b>Maximum Relative Humidity:</b> 90% at 50°C (non-condensing)
<b>Vibration and Mechanical Shock</b>	<b>Vibration:</b> 60 Hz, 30 minutes, 3 axes <b>Shock:</b> 30G for 11 milliseconds, half sine wave, 3 axes
<b>Application Note</b>	Allow 20-minute warm-up before programming or operating (see Sensor Setup, page 2)

## Hookups

### NPN Analog Current

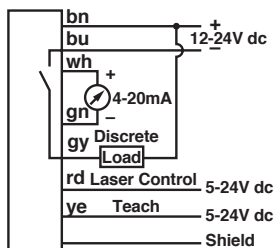

### PNP Analog Current

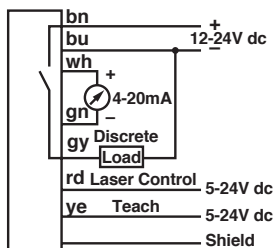

### NPN Analog Voltage

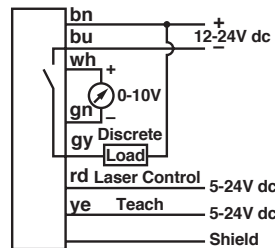

### PNP Analog Voltage

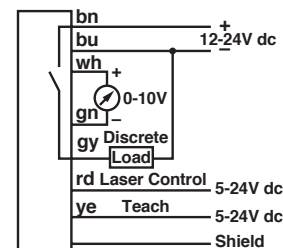

NOTE: Hookups for QD models are identical.

## Dimensions

### Mounting Hardware:

- M4 x 0.7 x 40 socket-head cap screw
- M4 x 0.7 hex nut with captured toothed lock washer
- M3 short arm hex key

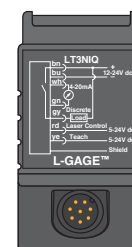
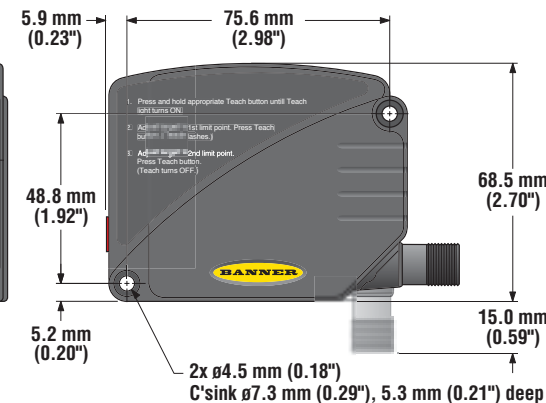
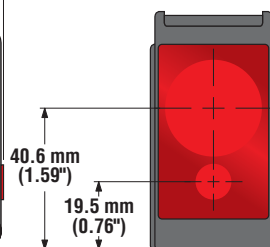
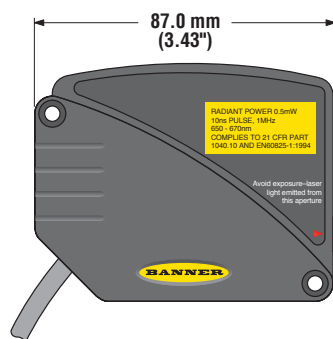
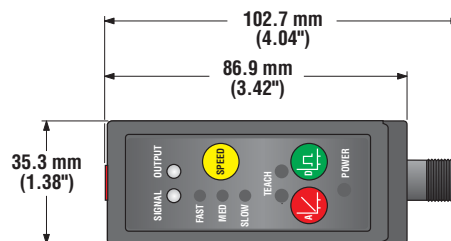

# LT3 Long-Range Time-of-Flight Laser Sensor – Analog/Discrete Outputs

## Mounting Brackets

**SMBLT31**

- Right-angle bracket
- 300 series stainless steel

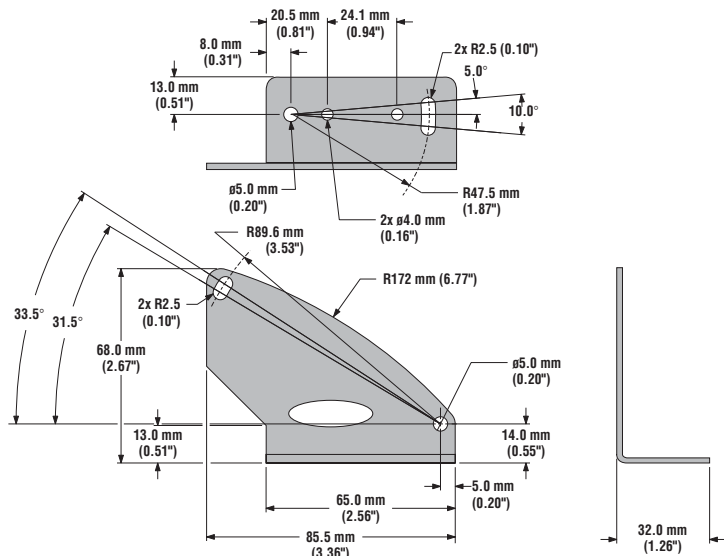

## Euro-Style Quick-Disconnect Cables

**Cable:** PVC jacket, polyurethane connector body, chrome-plated brass coupling nut

**Conductors:** 24 AWG high-flex stranded, PVC insulation, gold-plated contacts

**Temperature:** -40° to +105°C (-40° to +221°F)

**Voltage Rating:** 30V ac/36V dc

Style	Model	Length	Connector	Pin-Out (Female View)
8-Pin Euro Straight	MQDC-806 MQDC-815 MQDC-830	2 m (6.5') 5 m (15') 9 m (30')		

**WARRANTY:** Banner Engineering Corp. warrants its products to be free from defects for one year. Banner Engineering Corp. will repair or replace, free of charge, any product of its manufacture found to be defective at the time it is returned to the factory during the warranty period. This warranty does not cover damage or liability for the improper application of Banner products. This warranty is in lieu of any other warranty either expressed or implied.



**CAUTION . . .** This sensor contains no user-serviceable components. Do not attempt to repair.  
Incorrect component values may produce hazardous laser radiation levels.



### **WARNING . . . Not To Be Used for Personnel Protection**

**Never use these products as sensing devices for personnel protection. Doing so could lead to serious injury or death.**

These sensors do NOT include the self-checking redundant circuitry necessary to allow their use in personnel safety applications. A sensor failure or malfunction can cause either an energized or de-energized sensor output condition. Consult your current Banner Safety Products catalog for safety products which meet OSHA, ANSI and IEC standards for personnel protection.