

**Features**



- Visible Class 1 laser
- Narrow effective beam provides small-object detection and precise position control
- Crosstalk rejection algorithm protects against optical disturbance from adjacent sensors
- Excellent optical performance throughout sensing range, even close up
- 10 to 30V dc operation, with complementary (SPDT) NPN or PNP outputs, depending on model
- Bright LED operating status indicators are visible from 360°
- Compact, rugged sealed housing, protected circuitry
- Mounting versatility – popular 18 mm threaded barrel or side-mount
- Choose 2 m (6.5') or 9 m (30') cable or one of four QD options



Excellent for applications where high sensing power and small beam size are important. Uses a special filter to polarize the emitted light, filtering out unwanted reflections from shiny objects.

**Models**

Model	Sensing Beam and Range	Spot Size at Focus	Cable*	Output	Excess Gain	
					With Supplied Target BRT-51X51BM	With Supplied Target BRT-TVHG-2X2
QS18VN6LLP	650 nm Visible Red Class 1 Laser 0.1 to 10 m (0.33' to 33')	Approx. 4 mm at 10 m (0.16" at 33')	4-wire, 2 m (6.5') integral cable	NPN		
QS18VP6LLP				PNP		

\*Only standard 2m (6.5') cable models are listed. For 9 m (30') cable, add suffix "W/30" to the model number (e.g., QS18VN6LLP W/30).

**QD models:**

- For 4-pin integral Euro-style QD, add suffix "Q8" (e.g., QS18VN6LLPQ8).
  - For 4-pin integral Pico-style QD, add suffix "Q7" (e.g., QS18VN6LLPQ7).
  - For 4-pin Euro-style 150 mm (6") pigtail QD, add suffix "Q5" (e.g., QS18VN6LLPQ5).
  - For 4-pin Pico-style 150 mm (6") pigtail QD, add suffix "Q" (e.g., QS18VN6LLPQ).
- A model with a QD connector requires a mating cable (see page 4).

**⚠ WARNING . . . Not To Be Used for Personnel Protection**

Never use these products as sensing devices for personnel protection. Doing so could lead to serious injury or death. These sensors do NOT include the self-checking redundant circuitry necessary to allow their use in personnel safety applications. A sensor failure or malfunction can cause either an energized or de-energized sensor output condition. Consult your current Banner Safety Products catalog for safety products which meet OSHA, ANSI and IEC standards for personnel protection.



# WORLD BEAM® QS18LLP Series – Polarized Retroreflective Laser Sensors

## Installation Notes

Conventional retroreflective photoelectric sensors are extremely easy to align. Beam angles are wide, and retro targets are forgiving to the light beam's angle of incidence. The beam of this laser sensor is very narrow, compared with the beam of most retro sensors. As Figure 2 indicates, the effect of angular misalignment can be dramatic. Alignment is critical because the beam may miss the retroreflective target unless the target is large.

For example, with one BRT-51X51BM mounted at a distance of 6 m (20') from the sensor, one degree of angular misalignment will cause the center of the laser beam to miss the center of the target by 100 mm (4").

### Alignment Tip

When using a small retroreflective target at medium or long range, it is often useful to temporarily attach (or suspend) a strip of retroreflective tape (e.g., BRT-THG-2) along a line that intersects the actual target. The visible red laser beam is easily seen in normal room lighting on such tape. Sight along the beam toward the target (from behind the sensor). Move the sensor to sweep the laser beam back and forth across the retro tape strip. Use the tape strip to guide the beam onto the target.

Consider using sensor mounting bracket model SMB18SF or SMB3018SC (see page 5). A swivel bracket can simplify multiple-axis alignment. Alignment is complete when the visible image is centered on the retro target. The perpendicularity of the laser beam to the face of the retro target is forgiving, just as it is with a conventional retroreflective sensor.

### Effective Beam Size

Unlike conventional retroreflective sensors, the retroreflective laser has the ability to sense relatively small profiles. Figure 3 indicates the diameter of the smallest opaque rod which will reliably break the laser beam at several sensor-to-object distances. These minimum object sizes were measured with the sensor aligned to a BRT-51X51BM reflector and with the sensor set for an excess gain of about 10X. Flooding effects are possible when the gain is much higher. This means that sensor gain may have to be reduced in some situations in order to reliably detect these minimum object sizes.

Note that the shape of the beam is elliptical. The minimum object sizes listed assume passage of the rod across the major diameter of the ellipse (worst case). It may be possible to detect objects smaller than the sizes listed if the direction in which the objects pass through the beam can be controlled.



### CAUTION . . .

Never stare directly into the sensor lens. Laser light can damage your eyes. Avoid placing any mirror-like object in the beam. Never use a mirror as a retroreflective target.

### Retroreflector Recommendations

- **BRT-51X51BM** recommended for beam-block applications up to 10 m range.
- **BRT-TVHG-2X2** recommended for applications up to 1.5 m range. (This retroreflector is an adhesive-backed sealed tape with micro-prism geometry.)

Both reflectors are included with the sensor. See page 6 for information about ordering replacements or other reflector options.

NOTE: When sensing objects with specular reflections, use the sensor's side-mounting option to optimize sensing performance.

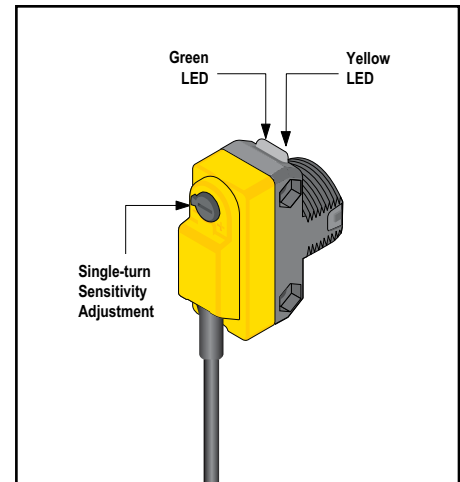
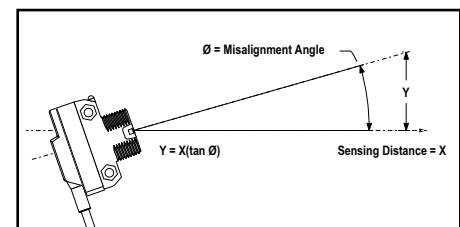

Figure 1. Sensor features



Sensor-to-Target Distance (X)	Beam Displacement (Y) for 1° of Misalignment
1.5 m (5')	25 mm (1")
3 m (10')	50 mm (2")
6 m (20')	100 mm (4")
10 m (33')	150 mm (6")

Figure 2. Beam displacement per degree of misalignment

Distance from Sensor to Object	Minimum Object Detection Size
0.3 m (1')	2.5 mm (0.10")
1.5 m (5')	5.0 mm (0.20")
3 m (10')	6.5 mm (0.26")
6 m (20')	10 mm (0.40")
10 m (33')	13 mm (0.52")

Figure 3. Minimum object detection size vs. distance from sensor

# WORLD BEAM® QS18LLP Series – Polarized Retroreflective Laser Sensors

## Specifications

<b>Supply Voltage</b>	10 to 30V dc (10% maximum ripple) at less than 15 mA, exclusive of load; Protected against reverse polarity and transient voltages
<b>Sensing Beam (Laser Characteristics)</b>	<b>Wavelength:</b> 650 nm visible red Class 1 laser <b>Pulse Width:</b> 7 microseconds <b>Rep Rate:</b> 130 microseconds <b>Average Output Power:</b> 0.065 milliwatts
<b>Output Configuration</b>	<b>Solid-state complementary (SPDT);</b> NPN or PNP (current sinking or sourcing), depending on model; <b>Rating:</b> 100 mA maximum each output at 25°C <b>Off-state leakage current:</b> <b>NPN:</b> less than 200 µA @ 30V dc <b>PNP:</b> less than 10 µA @ 30V dc  <b>ON-state saturation voltage:</b> <b>NPN:</b> less than 1.6V @ 100 mA <b>PNP:</b> less than 2.0V @ 100 mA  Protected against false pulse on power-up and continuous overload or short circuit of outputs
<b>Output Response</b>	700 microseconds ON/OFF NOTE: 200 ms max. delay on power-up; outputs do not conduct during this time
<b>Repeatability</b>	130 microseconds
<b>Hysteresis</b>	12% of range typical
<b>Adjustments</b>	Single-turn sensitivity (Gain) adjustment potentiometer
<b>Indicators</b>	2 LED indicators on sensor top: <b>Green ON steady:</b> Power ON <b>Yellow ON steady:</b> Light sensed <b>Green flashing:</b> Output overloaded <b>Yellow flashing:</b> Marginal excess gain (1.0 to 1.5x excess gain)
<b>Construction</b>	ABS housing, rated IEC IP67; NEMA 6; Acrylic lens cover 3 mm mounting hardware included
<b>Connections</b>	2 m (6.5') 4-wire PVC cable              4-pin Pico-style QD                      4-pin Euro-style QD 9 m (30') 4-wire PVC cable              4-pin Pico-style 150 mm (6") pigtail QD              4-pin Euro-style 150 mm (6") pigtail QD
<b>Operating Conditions</b>	<b>Temperature:</b> -10° to +50° C (+14° to +122° F) <b>Relative Humidity:</b> 90% @ 50° C (non-condensing)
<b>Laser Classification</b>	Class 1 laser product; complies with IEC 60825-1:2001 and 21 CFR 1040.10, except for deviations pursuant to Laser Notice 50, dated 7-26-01
<b>Certifications</b>	



### CAUTION . . . Do Not Disassemble for Repair

Use of controls or adjustments or performance of procedures other than those specified herein may result in hazardous radiation exposure. **Do NOT attempt to disassemble this sensor for repair.** A defective unit must be returned to the manufacturer.

## Description of Laser Class

### Class 1

Lasers that are safe under reasonably foreseeable conditions of operation, including the use of optical instruments for intrabeam viewing.

Reference IEC 60825-1:2001, section 8.2.

### Class 1 Laser Characteristics

(see specifications above)

### For Safe Laser Use:

- Do not permit a person to stare at the laser from within the beam.
- Do not point the laser at a person's eye at close range.
- Locate open laser beam paths either above or below eye level, where practical.

### CLASS 1 LASER PRODUCT

Complies with 21 CFR 1040.10 and 1040.11 except for deviations pursuant to Laser Notice No. 50, dated 7-26-01.



# WORLD BEAM® QS18LLP Series – Polarized Retroreflective Laser Sensors

## Dimensions

### Cabled Models

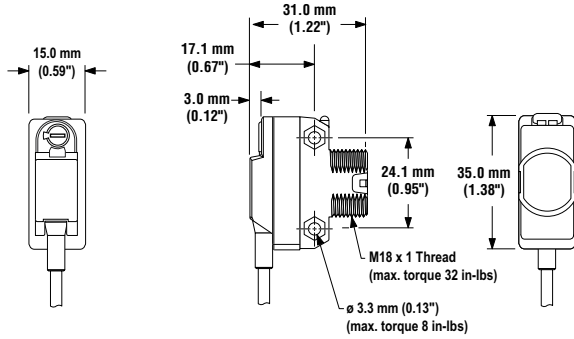

### QD Models

#### Model Suffix Q

#### Model Suffix Q5

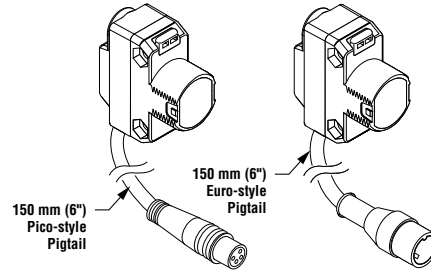

### Mounting Hardware (included)

#### Packing List:

- Sensor
- M18 x 1 jam nut
- M3 hardware packet
- BRT-51X51BM Reflector
- BRT-TVHG-2X2 Reflector

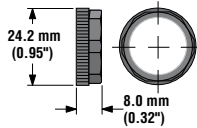

#### M3 Hardware Packet Contents:

- 2 – M3 x 0.5 x 20 mm SS Screw
- 2 – M3 x 0.5 SS Hex Nut
- 2 – M3 SS Washer

#### Model Suffix Q7

#### Model Suffix Q8

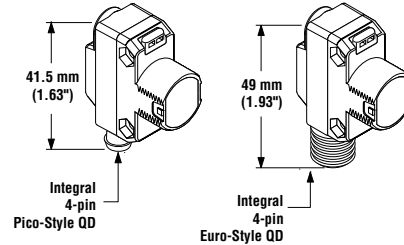

## Hookups

### NPN (Sinking) Outputs

### PNP (Sourcing) Outputs

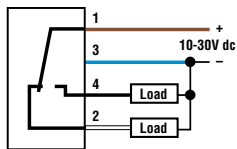
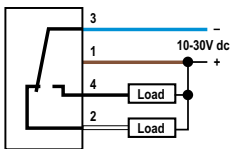

#### Key

- 1 = Brown
- 2 = White
- 3 = Blue
- 4 = Black

### 4-Pin Pico-Style Pinout

(Cable Connector Shown)

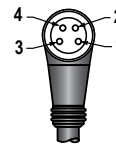

### 4-Pin Euro-Style Pinout

(Cable Connector Shown)

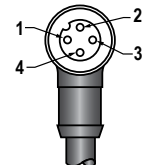

# WORLD BEAM® QS18LLP Series – Polarized Retroreflective Laser Sensors



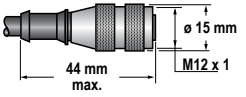
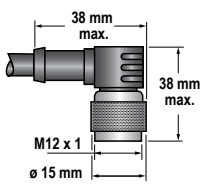



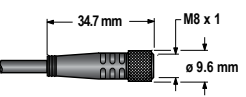
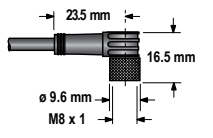

## Euro-Style Quick-Disconnect Cordsets

Style	Model	Length	Dimensions
4-Pin Straight	MQDC-406 MQDC-415 MQDC-430	2 m (6.5') 5 m (15') 9 m (30')	
4-Pin Right-angle	MQDC-406RA MQDC-415RA MQDC-430RA	2 m (6.5') 5 m (15') 9 m (30')	

## Pico-Style Quick-Disconnect Cordsets

Style	Model	Length	Dimensions
4-Pin Straight	PKG4-2	2 m (6.5')	
4-Pin Right-angle	PKW4Z-2	2 m (6.5')	

## Mounting Brackets

<b>SMB18A</b>	<ul style="list-style-type: none"> <li>• 12-gauge, stainless steel</li> <li>• Right-angle barrel-mount bracket</li> </ul>		<b>SMBQS18RA</b>	<ul style="list-style-type: none"> <li>• 14-gauge, 304 stainless steel</li> <li>• Right-angle side-mount bracket</li> </ul>	
<b>SMB312S</b>	<ul style="list-style-type: none"> <li>• Stainless steel</li> <li>• 2-axis, side-mounting bracket</li> </ul>		<b>SMB18FA</b>	<ul style="list-style-type: none"> <li>• 14-gauge, 304 stainless steel</li> <li>• 18 mm swivel bracket with tilt and pan movement for precision adjustment</li> </ul>	
<b>SMB46A</b>	<ul style="list-style-type: none"> <li>• 2-piece, 12-gauge, stainless steel bracket assembly with precision sensor alignment adjustment</li> <li>• Includes 2 mm hex key</li> </ul>		<b>SMBQS18Y</b>	<ul style="list-style-type: none"> <li>• Die-cast bracket for mounting into 18 mm holes</li> <li>• Metal hex nut and lock washer included</li> <li>• Cabled sensors tilt ±8°</li> </ul>	
<b>SMB18SF</b>	<ul style="list-style-type: none"> <li>• 18 mm swivel bracket</li> <li>• Black thermoplastic polyester</li> <li>• Includes stainless steel swivel locking hardware</li> </ul>		<b>SMBQS18A</b>	<ul style="list-style-type: none"> <li>• Nickel-plated die-cast zinc</li> <li>• Wrap-around bracket</li> </ul>	
<b>SMB3018SC</b>	<ul style="list-style-type: none"> <li>• 18 mm swivel side-mount bracket</li> <li>• Black reinforced thermoplastic polyester</li> <li>• Includes stainless steel swivel locking hardware</li> </ul>				

For bracket dimensions, visit [www.bannerengineering.com](http://www.bannerengineering.com).

# WORLD BEAM® QS18LLP Series – Polarized Retroreflective Laser Sensors

## Retroreflective Targets

Banner offers a wide selection of high-quality retroreflective targets. See the Accessories section of your current Banner Photoelectric Sensors catalog for complete information. NOTE: Polarized sensors require corner cube type retroreflective targets only. See Retroreflector Recommendations on page 2.



<p><b>BRT-51X51BM</b></p>	<ul style="list-style-type: none"> <li>• High-resolution corner-cube reflector (micro-prism)</li> <li>• 1.5 reflectivity factor*</li> <li>• Max. temp. +50° C (+122° F)</li> <li>• Supplied with sensor</li> </ul>	<p><b>BRT-TVHG-2X2</b></p> <ul style="list-style-type: none"> <li>• High-resolution corner-cube reflector (micro-prism) tape</li> <li>• 0.8 reflectivity factor*</li> <li>• Max. temp. +60° C (+140° F)</li> <li>• Supplied with sensor</li> </ul>	<p><b>BRT-35X35BM</b></p> <ul style="list-style-type: none"> <li>• High-resolution corner-cube reflector (micro-prism)</li> <li>• 1.2 reflectivity factor*</li> <li>• Max. temp. +65° C (+149° F)</li> <li>• Option for smaller spaces</li> </ul>

\*Reflectivity factor when compared with the standard BRT-3 reflector



P/N 118900 rev. B

**WARRANTY:** Banner Engineering Corp. warrants its products to be free from defects for one year. Banner Engineering Corp. will repair or replace, free of charge, any product of its manufacture found to be defective at the time it is returned to the factory during the warranty period. This warranty does not cover damage or liability for the improper application of Banner products. This warranty is in lieu of any other warranty either expressed or implied.