

SM51 Series Opposed Mode Sensors

DC sensors with metal housings: SM51EB/RB, SM51EB6/RB6



Banner SM51 Series dc opposed mode sensors are designed for reliable performance in especially hostile industrial environments. These models have totally-encapsulated circuitry within die-cast metal housings for superior resistance to moisture and physical abuse. Models include: SM51EB/SM51RB and SM51EB6/SM51RB6.

The narrow, 1/2" wide housing design has gained this family of sensors the nickname of "the flatpack". Like the MINI-BEAM, this design allows multiple SM51 Series sensors to be easily stacked together side-by-side on 1/2" centers for "curtain of light" or code reading applications.

SM51 Series receivers have *complementary* NPN transistor outputs (one normally open and the other normally closed), which connect directly to Banner MICRO-AMP and MAXI-AMP logic modules, as well as to most logic gates, small relays, and other similar dc loads.

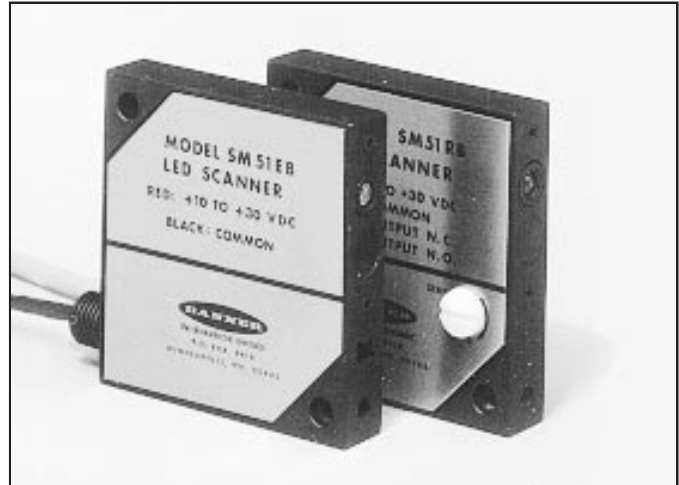

SPECIFICATIONS

- RANGE:** See excess gain curves in individual product descriptions.
- SUPPLY VOLTAGE:** 10-30V dc. Max. allowable ripple 10%; supply current is typically less than 50 mA (emitter) and 25 mA (receiver, exclusive of load).
- RECEIVER OUTPUT CONFIGURATION:** SM51RB has complementary open-collector NPN transistors (one normally open and one normally closed). SM51RB6 has normally open output only. Continuous short-circuit protection. Reverse polarity protection.
- RECEIVER OUTPUT RATING:** Each output transistor is capable of sinking up to 250mA continuously. On-state saturation voltage less than 2 volts at full load and less than 1 volt at signal levels. Off-state leakage current less than 100 microamps. Outputs are reverse-polarity protected.
- RESPONSE TIME:** See individual specifications. Response time is independent of signal strength.
- REPEATABILITY:** See individual specifications. Repeatability is independent of signal strength.

- OPERATING TEMPERATURE:** -40 to +70 °C (-40 to +158 °F).
- CONSTRUCTION:** Die-cast metal housing with stainless steel legend plate. Totally encapsulated. NEMA 1, 2, 3, 3S, 4, 4X, 12, and 13. Cables are .15-inch diameter, PVC covered, shielded (4 conductor, 6 ft. long).
- INDICATOR LED:** Red LED indicator at rear of receiver (above cable exit) lights when the receiver is seeing a "light" signal.
- SENSITIVITY ADJUSTMENT:** Single-turn adjustment, accessible by removing the nylon screw on the side of the receiver.

APPLICATION WARNINGS:

Outputs will not directly interface TTL logic, due to the reverse-polarity protection diode. Contact the factory for TTL interfacing instructions. The short-circuit protection may de-energize the outputs with certain incandescent light bulb or capacitive loads. Contact the factory if these loads are anticipated.

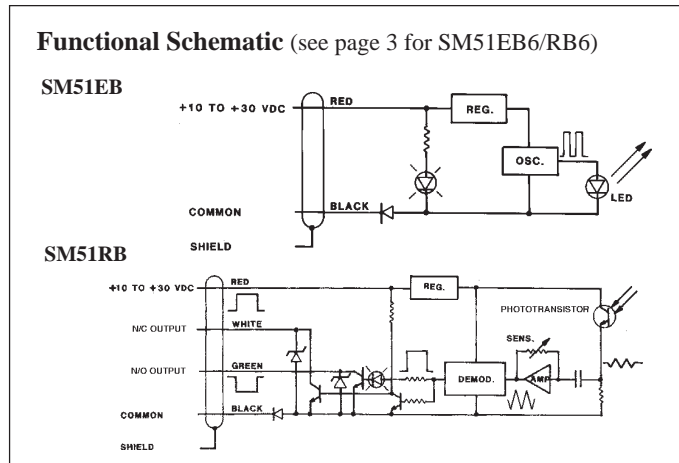
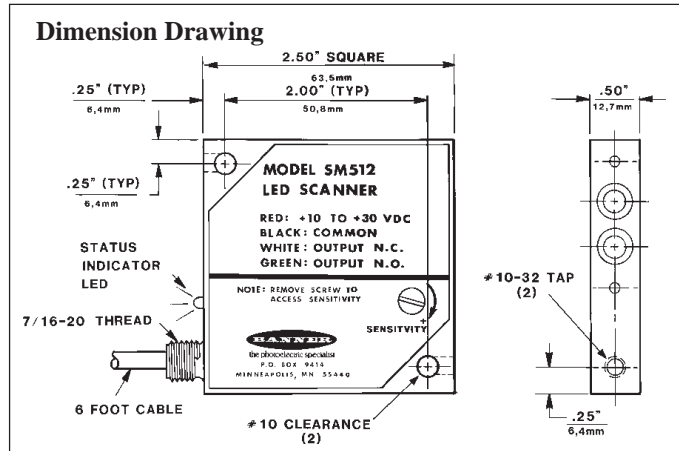

WARNING These photoelectric presence sensors do NOT include the self-checking redundant circuitry necessary to allow their use in personnel safety applications. A sensor failure or malfunction can result in *either* an energized or a de-energized sensor output condition. Never use these products as sensing devices for personnel protection. Their use as safety devices may create an unsafe condition which could lead to serious injury or death.

Only MACHINE-GUARD and PERIMETER-GUARD Systems, and other systems so designated, are designed to meet OSHA and ANSI machine safety standards for point-of-operation guarding devices. No other Banner sensors or controls are designed to meet these standards, and they must NOT be used as sensing devices for personnel protection.

SM51 Series Opposed Mode Sensors

SM51EB/SM51RB

Opposed mode

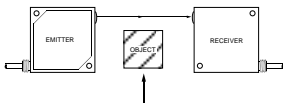

VOLTAGE: 10-30V dc
RANGE: 25 feet (8 meters)
RESPONSE TIME: 1 millisecond
REPEATABILITY: 0.1 millisecond
SENSING BEAM: infrared, 880nm
EFFECTIVE BEAM: 0.14" dia.

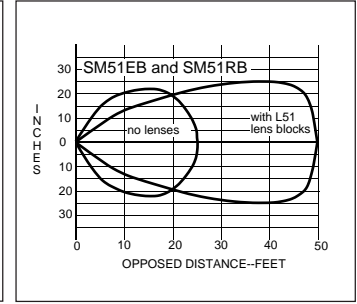
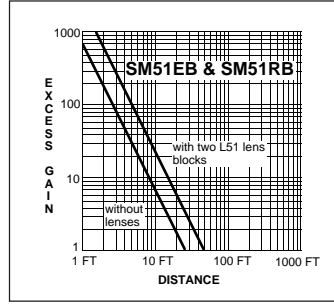

The **fast response time and small effective beam** of this opposed mode sensor pair makes it an excellent choice for sensing small, fast-moving objects over a range of up to 25 feet. Accessory lens block model L51 may be added to either the emitter or receiver or both for extended range. Alternatively, sensors may be purchased with the lens blocks already installed (order models SM51EBL and SM51RBL). With lens blocks attached, this pair will reliably sense objects with 3/8" or larger profiles. The SM51EB and SM51RB also may be fitted with aperture block model L52AB to resolve profiles as small as .040" at shorter sensing ranges. The circuitry of the SM51EB and SM51RB is **compatible with the model MP-8 multiplexer module** to create "curtains of light" for sensing or for measuring objects that pass anywhere through a sensing plane.

Hookup to Load (SM51RB receiver)

Hookup of SM51RB Receiver to Relay or Solenoid

Receiver SM51RB offer two open collector NPN outputs in a complementary configuration (one normally open and one normally closed). The green output wire switches the load when the receiver "sees" its modulated light source (LIGHT operate). The white output wire switches in the dark condition (DARK operate). Both output circuits can switch up to 1/4 amp.

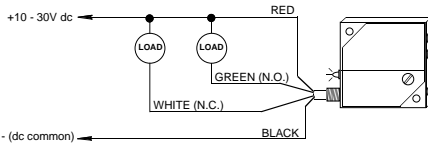

Hookup of SM51RB Receiver Sensor to Counter

Most counters, totalizers, rate meters, etc. accept either output of the SM51RB. Hookup to a battery-powered LCD type is shown here. For other types, follow the counter's hookup instructions for an NPN or current sinking input device.

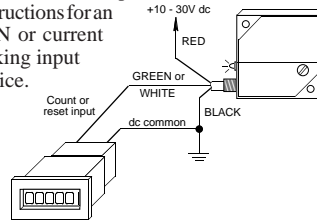

Hookup of SM51EB Emitter

Emitter model SM51EB connects directly to a dc power supply, as shown.

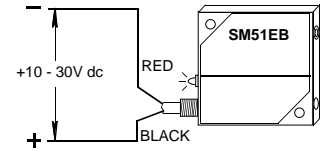

Hookup of SM51RB Receiver to Programmable Controller requiring current sink

Either sensor output is wired directly to any input of the PLC. Also, connect the negative of the sensor power supply to the negative of the PLC (input card) power supply (if they are separate supplies).

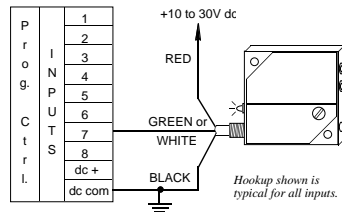

Hookup of SM51RB Receiver to Programmable Controller requiring current source

Either sensor output is wired to any input of the PLC. An external "pullup" resistor is connected between the input and +V of the PLC (input card) power supply. The value of the resistor is not critical: values from 1KΩ to 10KΩ, 1/4 watt or larger, will satisfy most inputs. Also, connect the negative of the sensor power supply to the negative of the PLC (input card) power supply (if they are separate supplies).

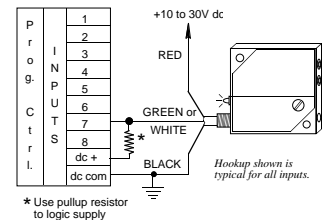

Hookup to MAXI-AMP Logic (CL Series modules)

The output of an SM51RB receiver may be used as an input to Banner MAXI-AMP CL Series logic modules. The MAXI-AMP, when powered by AC voltage, offers a DC supply with enough capacity to power one SM51 Series sensor. An SM51RB receiver may also be used as an input to the auxiliary input of a CL5 module.

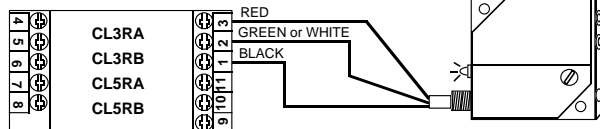

Hookup to MICRO-AMP Logic (MPS-15 Chassis)

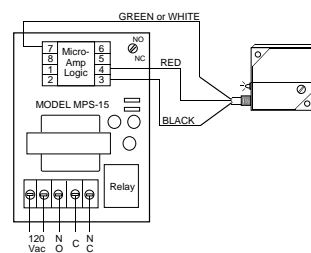

The output (green or white wire) of an SM51RB receiver connects directly to any input of Banner MICRO-AMP logic-only modules. These MICRO-AMP logic modules may be used:

- MA4-2 One-shot
- MA5 Delay
- MA4G 4-input "AND"
- MA4L Latch

SM51 Series Opposed Mode Sensors

SM51EB6 & SM51RB6

Opposed (non-fiberoptic),
Opposed fiberoptic, and
Diffuse fiberoptic modes

VOLTAGE: 10-30V dc
RANGE: 100 feet in opposed
mode (non-fiberoptic).

See excess gain curves for fiberoptic range information.

RESPONSE TIME: 10 milliseconds

REPEATABILITY: 1 millisecond

SENSING BEAM: infrared, 880nm



The SM51EB6/SM51RB6 opposed mode sensor pair is a **very high gain** emitter/receiver pair that utilizes an interconnecting synchronizing wire to "gate" the receiver to look for a signal only at the instant when the emitter sends a pulse from its LED. Because of the high power of these sensors, they are often used to "burn through" an opaque container (a cereal box, for example) to determine if contents are present. Special optics enable them to do this job even better than other sensors which may appear to have more excess gain (such as the MULTI-BEAM SBEX and SBRX1). NOTE: lens blocks may be removed for short-range "burn-through" applications.

This sensor pair may also be used with fiber optics by adding the optional FOF500 fittings (or order sensor models SM51EB6FO and SM51RB6FO). When used this way, they provide several times more excess gain than the conventional SM512LBFO. Range when used in the opposed mode with IT23S individual fibers is 7 feet. Sensing range may be extended by use of L9 or L16F lenses (see excess gain curves).

NOTE: the gain of this sensor pair is too high for use with a bifurcated fiber assembly. The very small amount of light that "leaks" through the fiber cladding within the bifurcated bundle is typically enough to operate the high-gain receiver.

For diffuse (proximity) sensing, position two individual fibers side-by-side with the sensing tips parallel to each other or mechanically converged towards the desired sensing point.

The receiver has a normally open output only (green wire); the white wire is used to synchronize the emitter. NOTE: for normally closed output, order special receiver model SM51RB6DO (DO = Dark Operate).

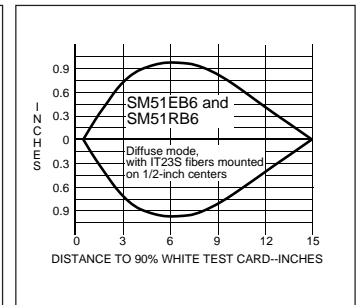
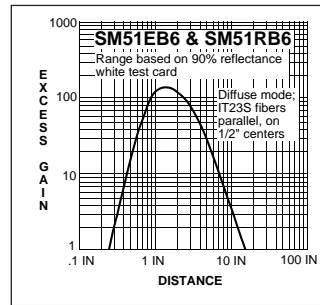
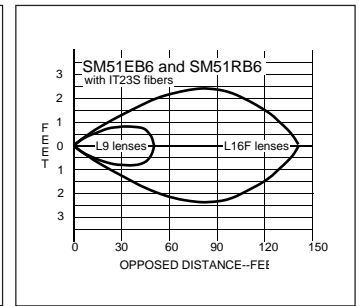
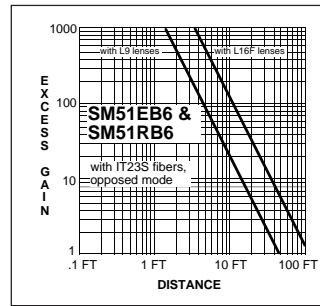
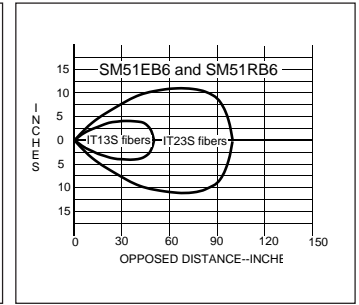
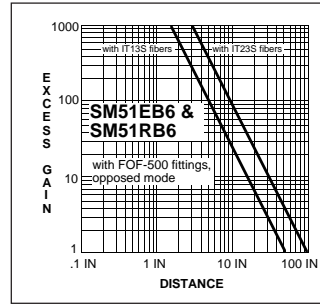
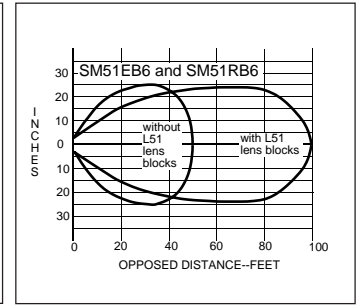
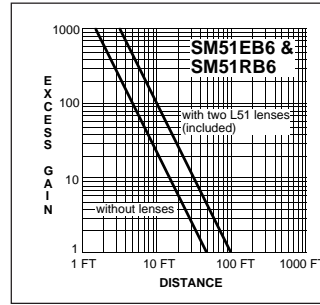

Hookup Diagram

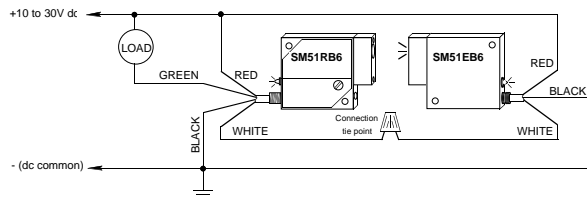

Both the emitter and receiver have white wires which connect together to synchronize (lock on) the pair to a narrow frequency bandwidth. These white wires *must* be connected together if the sensor pair is to operate at high gain. There is only one receiver output, which is the same NPN current sinking circuit used in the other SM512 Series sensors.

The output is normally open (or LIGHT operate). For a normally closed output, specify model SM51RB6DO (DO = Dark Operate).

Functional Schematic

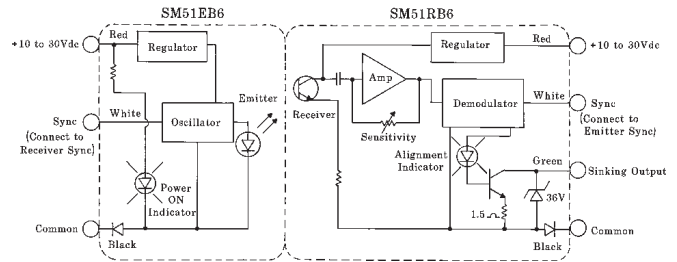

SM51 Series Opposed Mode Sensors

Accessories and Modifications for SM51 Series Sensors



SMB500

Universal steel mounting bracket for 51 Series sensors permits adjustment in both axes. Also available in stainless steel (order model SMB500SS).



RAR500

Right-angle beam deflector used to reflect the light beam at 90 degrees to the sensor package. Range is reduced by about 50% when using the RAR500.



BZ500

Plastic lens cover for any 51 Series sensor that does not utilize a lens block. Used in food applications where the presence of a glass lens is unacceptable.



L51

For extending the range of any of the 51 Series emitters and receivers. When used on both emitter and receiver, typically doubles the range of unlened units.

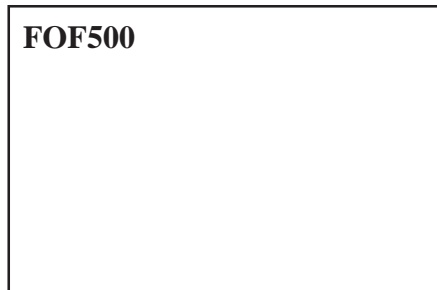

FOF500

Fiberoptic interface block. Creates fiberoptic sensor from emitter/receiver pairs. Contact factory for ranges.



CF7-16

Aluminum compression fitting for the cable entrance at the rear of the 51 Series sensors. May be used with either plastic or flexible steel conduit (PVC-6 or AC-6).

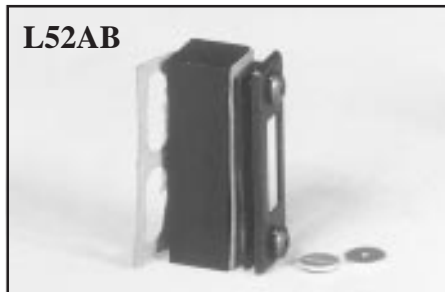

L52AB

Model L52AB (right) is an aperture block used with any of the 51 Series emitters and receivers to create very narrow effective beams.

Each L52AB comes with a .040-inch diameter round aperture and a .030 x .125-inch rectangular aperture. The aperture blocks include sealed clear windows to prevent the apertures from becoming clogged with dirt.

Apertures are normally used on both the emitter and receiver.

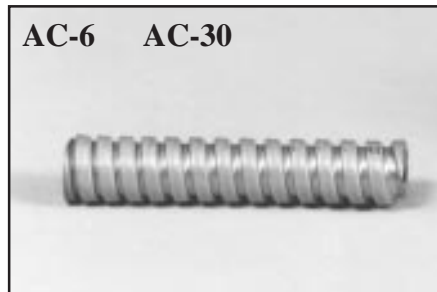

AC-6 AC-30

These are 6 and 30-foot lengths of flexible steel conduit and may be used with any of the 51 Series sensors and the CF7-16 fitting to provide protection to the sensor cable. Size: I.D. = 5/16"; O.D. = 7/16".

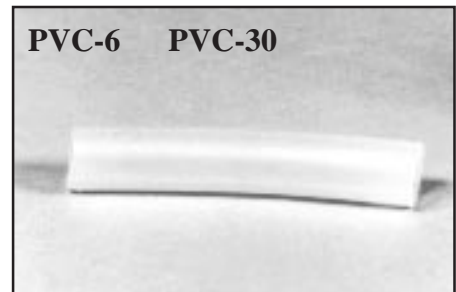

PVC-6 PVC-30

6 and 30-foot lengths of plastic (PVC) flexible tubing for use with the 51 Series sensors and the CF7-16 in food applications where flexible steel conduit is not allowed. Size: I.D. = 1/4"; O.D. = 3/8".

WARRANTY: Banner Engineering Corporation warrants its products to be free from defects for one year. Banner Engineering Corporation will repair or replace, free of charge, any product of its manufacture found to be defective at the time it is returned to the factory during the warranty period. This warranty does not cover damage or liability for the improper application of Banner products. This warranty is in lieu of any other warranty either expressed or implied.

Modification Information for SM51 series Sensors

These modifications are available for SM51 Series sensors. They are not stocked, but are available on a "quote" basis:

HIGH SPEED Modification (model Suffix "MHS")

SM51RB receivers with normal response speed of 1 millisecond may be modified for faster response. Modification "MHS" offers 300 microsecond (0.3 millisecond) on and off response time. This modification is most often used when very small targets must be

sensed. **Repeatability** of SM51RBMHS model is 0.03 millisecond.

CABLE LENGTH Modification (30-foot cable)

Any of the SM51 Series sensors may be built with a cable longer than the standard 6-foot length. The most readily available length is 30 feet. Lengths longer than 30 feet may also be quoted.