

## Features



- Special emitter/receiver infrared wavelength tuned to the absorption band of water
- Powerful enough to burn through many types of plastic and glass containers
- Water-based liquids will attenuate the signal; this enhances contrast on difficult sensing applications found on bottle-filling lines
- Excellent noise immunity and crosstalk avoidance
- Easy-to-read operating status indicators
- Bipolar discrete outputs, PNP and NPN; analog model also available
- Light Operate and Dark Operate models available
- Models available with 2 m or 9 m (6.5' or 30') cable, or 150 mm (6") pigtail with quick-disconnect fitting
- Rugged IP67 housing for harsh environments; encapsulated electronics
- Compact housing, mounting versatility — 30 mm threaded barrel- or side-mount

## Models

Model	Description	Sensing Beam and Range <sup>†</sup>	Supply Voltage	Output
QS30EXH2O	Emitter	1450 nm infrared 13 mm effective beam dia.	10 to 30V dc	—
QS30ARH2O	Receiver, light operate	2 m (6') range		
QS30RRH2O	Receiver, dark operate			
QS30ARXH2O	High-gain receiver, light operate	4 m (12') range		
QS30RRXH2O	High-gain receiver, dark operate			
QS30RXH2OU	High-gain receiver, analog		15 to 30V dc	0-10V Analog

\* Only 2 m (6') cables are listed. For 9 m (30') cable, add suffix "W/30" to the model number (e.g., QS30EH2O W/30).

For 150 mm (6.5") pigtail with a 5-pin Euro-style connector, add suffix "Q5" to the model number (e.g., QS30EH2OQ5). A model with a QD connector requires a mating cordset (see page 7).

<sup>†</sup> Sensors can be used at ranges greater than listed for applications that require less excess gain. Please consult the factory for assistance on your long-range applications.

**⚠ WARNING . . . Not To Be Used for Personnel Protection**

**Never use these products as sensing devices for personnel protection. Doing so could lead to serious injury or death.**

These sensors do NOT include the self-checking redundant circuitry necessary to allow their use in personnel safety applications. A sensor failure or malfunction can cause either an energized or de-energized sensor output condition. Consult your current Banner Safety Products catalog for safety products which meet OSHA, ANSI and IEC standards for personnel protection.



# WORLD BEAM® QS30H2O Series Water Sensor

## Overview

The Banner QS30H2O series water sensor was developed to detect the presence of water. Its electro-optical components are tuned to one absorption band of water in the long infrared spectrum. The emitted infrared light penetrates many types of plastic and glass containers, but will not pass through water-based fluids, nor through opaque substances such as wood, metal or cardboard. Accessory apertures are available to attenuate or shape the beam for low-gain applications, for example, clear water in a clear bottle.

Low-gain models are recommended for sensing applications where the liquid container is transparent or when the thickness of liquid being detected is small. Some examples are clear glass test tubes and clear PET beverage bottles. High-gain models are recommended when the liquid container is light-blocking (translucent) and when the thickness of liquid being detected is large. Some examples are HDPE milk containers, colored PET beverage bottles, and etched glass containers.

For all applications, the sensors must be installed to maximize the optical contrast between the clear and blocked states. The installer can use apertures and mechanical alignment of the sensors to achieve the best results (see page 3). The QS30H2O sensor enhances the available contrast by taking advantage of the absorption band of water.

For advanced applications, a 0–10V analog output is available. The analog output allows the user to directly measure the amount of signal attenuation. The analog output value can be filtered and a switching threshold determined in a PLC or computer as required for the application. Please consult the factory for more information on using the analog output.

Each discrete output model has two bipolar outputs that switch simultaneously: one each NPN (sinking) and PNP (sourcing). Light Operate and Dark Operate models are available.

The versatile housing provides multiple mounting configurations in a minimum of space. These sensors are extremely rugged, powerful and leakproof, with epoxy-encapsulated electronics for maximum resistance to mechanical shock and vibration. They are powerful enough to burn through dust and many types of industrial and process contamination.

The sensors' innovative circuitry provides excellent EMI/RFI noise immunity. For applications where optical crosstalk between multiple sensor pairs may be a problem, either of two modulation frequencies may be selected. (Set each emitter to the same frequency as its receiver, via the sensor hookup; see configuration on page 3 or hookups on page 6.)

### Indicators

Each sensor has a green Power ON/OFF indicator, visible from 360° (see Figure 1). Receivers also have a yellow AID indicator that flashes to show signal strength. (The higher the flash rate, the more light is received; a solid AID LED indicates excellent signal.) Discrete models also have a large yellow LED that lights when an output is conducting.

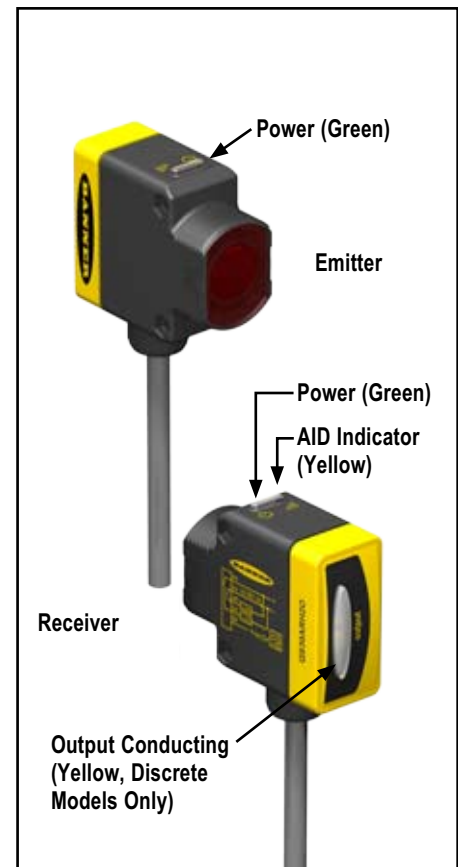

Figure 1. Features

## Sensor Configuration

### Teaching Limits

Discrete models require no configuration; simply align the emitter to the receiver to maximize contrast between the clear and blocked conditions (see procedure on page 3).

For analog models in high-contrast applications, alignment may be the only configuration needed. For more challenging applications using analog models, use the TEACH procedure to maximize contrast. This procedure is accomplished by pulsing the receiver's white wire (see hookups on page 6 and procedure on page 4). Analog output slope also can be inverted from positive to negative or back again.

# WORLD BEAM® QS30H2O Series Water Sensor

## Sensor Alignment — When Empty Container Can Be Presented

1. Position both the emitter and the receiver loosely in their mounting position. See Figure 2.
2. Present the “clear” condition for the application (an empty container).
3. Verify that both emitter and receiver are wired for the same modulation frequency (see below).
4. Adjust the emitter first, then the receiver. Adjust the emitter's position until the receiver AID indicator is ON steady, or is flashing at its fastest rate.
5. Tighten the emitter mounting hardware, then repeat step 4 for the receiver.
6. Block the sensor beam with the target and verify that the output changes state.

## Sensor Alignment — When Empty Container Cannot Be Presented

For this procedure, the clear condition is no container at all.

1. Mount loosely and mechanically align the emitter and the receiver such that their faces are parallel to one another. (The AID indicator should be ON steady.)
2. Rotate the emitter in one direction until the receiver AID indicator begins to flash. Repeat in the other direction. Position the emitter midway between those two positions and tighten the emitter mounting hardware.
3. Repeat step 2 for the receiver.
4. Block the sensor beam with the target and verify that the output changes state.

## Frequency Selection

The modulation frequency (A or B) is selected by the state of the gray wire (on cabled models; pin 5 on QD models — see hookups, page 4). A “+” voltage or no connection selects frequency A; connecting it to “-” selects frequency B. Each emitter must be set to the same frequency as its receiver.

## Emitter Inhibit

To disable (or inhibit) the emitter LED (useful for testing the receiver operation), connect the white wire to “-” voltage.

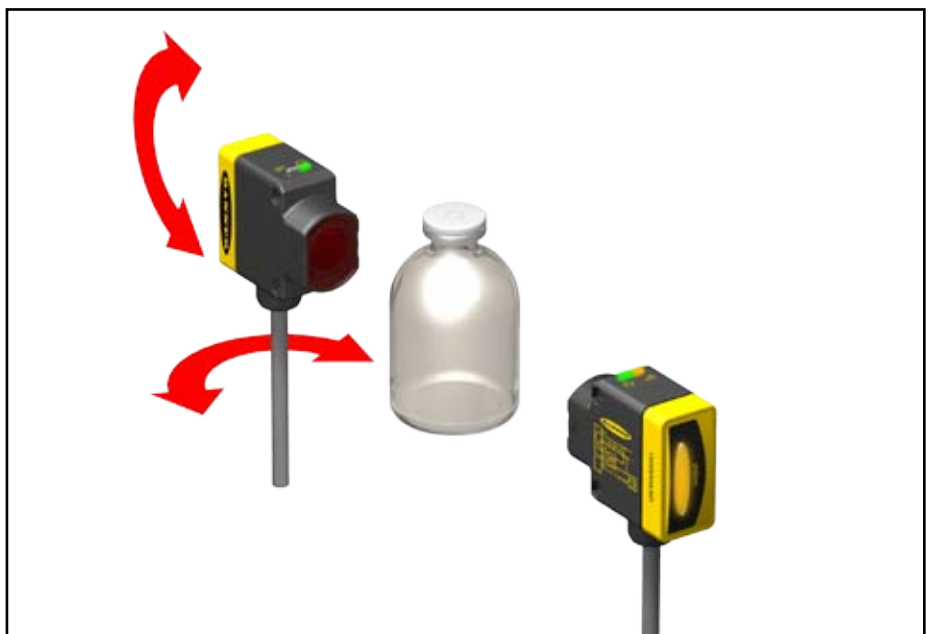

Figure 2. Sensor alignment procedure

# WORLD BEAM® QS30H2O Series Water Sensor

## Analog Static TEACH

- Analog TEACH is performed remotely, by pulsing the white Teach wire (see Hookups).

**Restore Factory TEACH:** Reverts the sensing limits to the factory default limits (max contrast); output slope is not affected.

**Analog Output Slope:** Toggles the analog output to send a high signal when object is absent (positive slope) or present (negative slope). Analog slope can be selected based on the TEACH order (first taught condition is always 0V; second taught condition is 10V) or by using the slope select procedure below. If the slope select procedure is used, it must be used *after* teaching the limits. To determine the current slope setting, measure the output signal during object present and absent conditions.

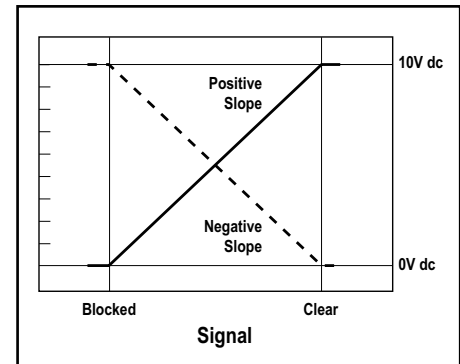

Figure 2. Analog Static TEACH

Step	Remote Line $0.04 \text{ seconds} \leq T \leq 0.8 \text{ seconds}$	Result
<b>Access TEACH Mode/ Learn 1st Condition</b>	<ul style="list-style-type: none"> <li>• Present 1st condition</li> <li>• Single-pulse remote TEACH line</li> </ul>	<b>Power LED:</b> OFF <b>AID LED:</b> Double-flash
<b>Learn 2nd Condition</b>	<ul style="list-style-type: none"> <li>• Present 2nd condition</li> <li>• Single-pulse remote TEACH line</li> </ul>	<b>TEACH Accepted</b> <b>Power LED:</b> Flashes 3 times, then ON <b>AID LED:</b> AID mode (flash rate varies depending upon signal strength) Sensor returns to RUN mode.
		<b>TEACH Not Accepted</b> <b>Power LED:</b> OFF <b>AID LED:</b> Single-flash Sensor returns to "Learn 1st Condition."

## Restore Factory Default (Maximum Contrast) Setting

Step	Remote Line $0.04 \text{ seconds} \leq T \leq 0.8 \text{ seconds}$	Result
<b>Access TEACH Mode</b>	<ul style="list-style-type: none"> <li>• Single-pulse remote TEACH line</li> </ul>	<b>Power LED:</b> OFF <b>AID LED:</b> Double-flash
<b>Restore Factory Default Setting (Maximum Contrast Setting)</b>	<ul style="list-style-type: none"> <li>• Double-pulse remote TEACH line</li> </ul>	<b>Power LED:</b> Flashes 3 times, then ON <b>AID LED:</b> AID mode (flash rate varies depending upon signal strength) Sensor returns to RUN mode with maximum contrast setting.

## Analog Output Slope Invert

Teach sensing limits before inverting the output slope.

Step	Remote Line $0.04 \text{ seconds} \leq T \leq 0.8 \text{ seconds}$	Result
<b>Toggle Analog Output Slope</b>	<ul style="list-style-type: none"> <li>• Triple-pulse remote TEACH line</li> </ul>	Analog output slope toggles between positive and negative.

# WORLD BEAM® QS30H2O Series Water Sensor

## Specifications

NOTE: Specifications are subject to change without notice.

<b>Supply Voltage</b>	<b>Emitter:</b> 10 to 30V dc (10% maximum ripple) at less than 80 mA <b>Discrete Receiver:</b> 10 to 30V dc (10% maximum ripple) at less than 65 mA (exclusive of load) <b>Analog Receiver:</b> 15 to 30V dc (10% maximum ripple) at less than 65 mA (exclusive of load)
<b>Beam</b>	1450 nm, infrared 13 mm effective beam diameter
<b>Sensing Range</b>	<b>Low-gain models:</b> 2 m (6.5') <b>High-gain models:</b> 4 m (13')
<b>Output Configuration</b>	<b>Discrete models:</b> Bi-polar current sinking (NPN) white wire; current sourcing (PNP) black wire <b>Analog models:</b> 0–10V (black wire)
<b>Output Rating</b>	<b>Discrete models:</b> 100 mA maximum load @ 25° C <b>OFF-state leakage current:</b> less than 10 µA <b>ON-state saturation voltage:</b> <b>PNP:</b> less than 1.2V at 10 mA; less than 2.5V at 100 mA <b>NPN:</b> less than 200 mV at 10 mA; less than 1V at 100 mA Protected against false pulse on power-up and continuous overload or short circuit <b>Analog models:</b> 2 KΩ minimum impedance
<b>Output Response</b>	<b>Discrete models:</b> <b>10x excess gain or more</b> — 1 ms ON and OFF response; 500 µs repeatability <b>2x to 10x excess gain</b> — 3 ms ON and OFF response; 2.5 ms repeatability <b>Analog models:</b> 25 ms for a 95% step change
<b>Adjustments</b>	<b>Light Operate/Dark Operate</b> — depending on model selected <b>Frequency</b> — selected via gray wire <b>A:</b> Gray (+) <b>B:</b> Gray (-) <b>Emitter only:</b> LED inhibit — selected via white wire White (-) turns emitter LED OFF (to allow verification of receiver operation)
<b>Indicators</b>	<b>Green LED on housing top:</b> Power ON <b>Receiver only:</b> <b>Yellow AID LED on housing top:</b> Flashes to indicate signal strength (faster flash = better signal) <b>Yellow LED (large oval on housing back):</b> Discrete output conducting
<b>Environmental Rating</b>	IEC IP67 (NEMA 6) and 1200 psi washdown NEMA ICS 5, Annex F-2002
<b>Construction</b>	PC/ABS plastic housing; acrylic window
<b>Connection</b>	5-wire 2 m or 9 m cable (6' or 30') or 150 mm (6") pigtail with 5-pin Euro-style quick-disconnect fitting
<b>Operating Conditions</b>	<b>Temperature:</b> -20° to +60°C (-4° to +140°F) <b>Relative Humidity:</b> 95%; non-condensing
<b>Certifications</b>	Approvals in process

## Performance Curves

**Excess Gain**

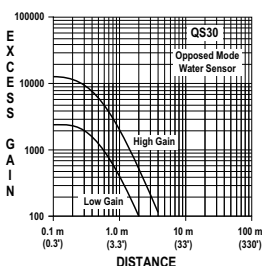

**Beam Pattern**

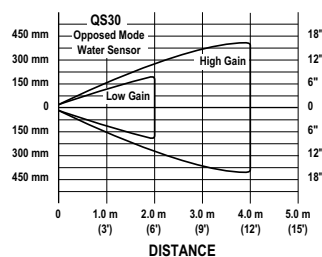

**H<sub>2</sub>O Thickness vs. Excess Gain**  
(Typical for Distilled Water, 100% Blocked Condition)

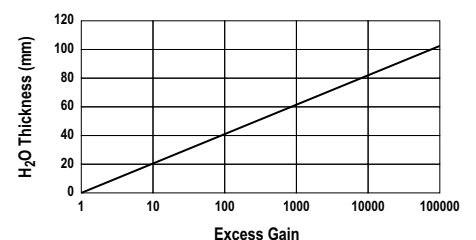

# WORLD BEAM® QS30H2O Series Water Sensor

## Dimensions

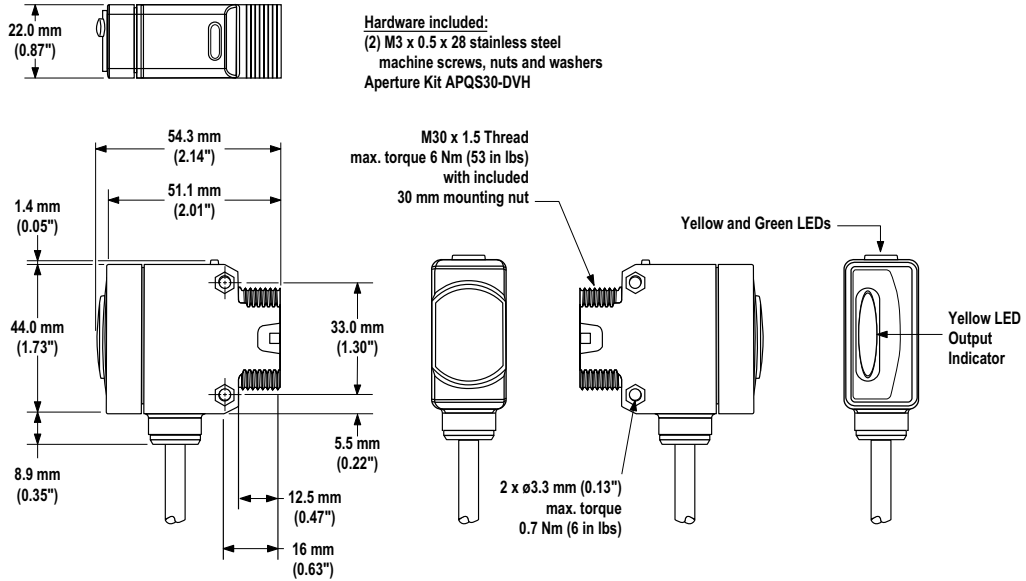

## Hookups

**Emitter**  
**Frequency A**

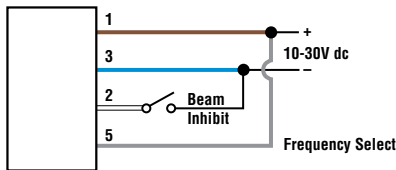

**Receiver — Discrete**  
**Frequency A**

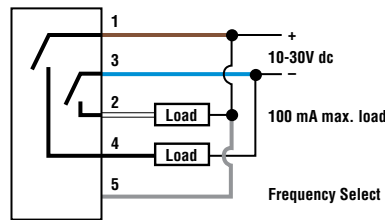

**Receiver — Analog**  
**Frequency A**

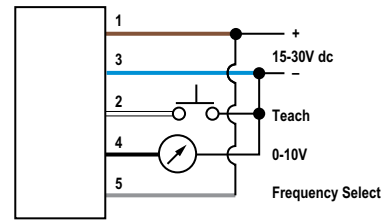

**Frequency B**

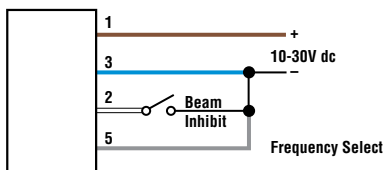

**Frequency B**

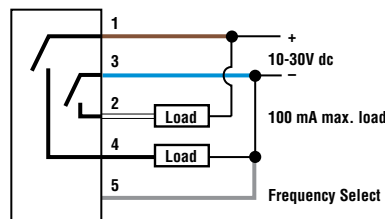

**Frequency B**

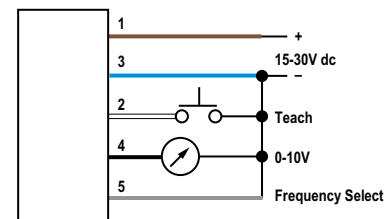

**Key**

- 1 = Brown
- 2 = White
- 3 = Blue
- 4 = Black
- 5 = Gray

**Cable and QD hookups are functionally identical.**





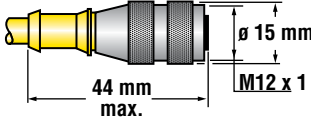
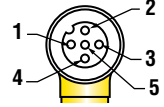

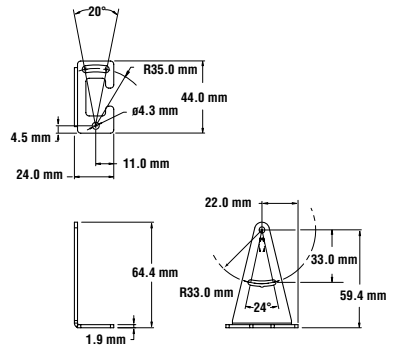

# WORLD BEAM® QS30H20 Series Water Sensor

## Quick-Disconnect Cordsets

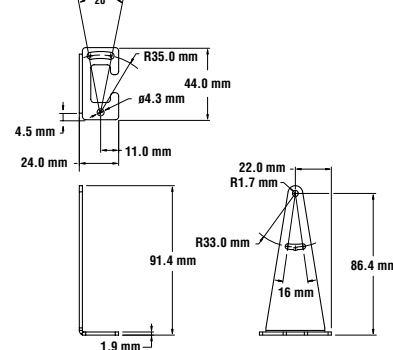
Style	Model	Length	Dimensions	Pinout
5-pin Euro-style straight	MQDC1-506 MQDC1-515 MQDC1-530	2 m (6.5') 5 m (15') 9 m (30')		

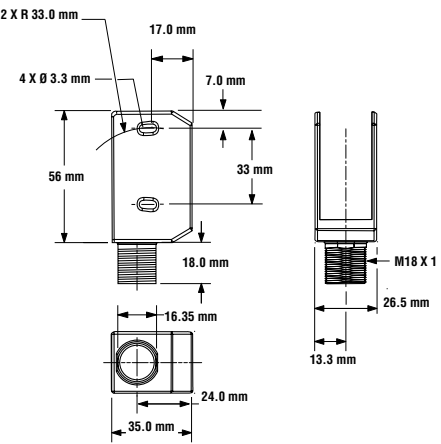
## Mounting Brackets

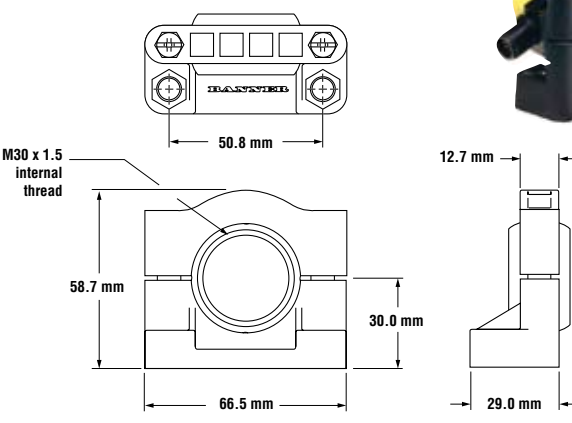
NOTE: Other sensor models shown on some views below.

<p><b>SMBQS30L</b></p> <ul style="list-style-type: none"> <li>• Right-angle bracket for cabled sensors</li> <li>• 14-gauge stainless steel</li> <li>• <math>\pm 12^\circ</math> tilt adjustment</li> <li>• Clearance for M4 (#8) hardware</li> </ul>	<p><b>SMBQS30LT</b></p> <ul style="list-style-type: none"> <li>• Tall right-angle bracket for QD sensors with straight cordset connectors</li> <li>• 14-gauge stainless steel</li> <li>• <math>\pm 8^\circ</math> tilt adjustment</li> </ul>
 	 
<p><b>SMBQS30Y</b></p> <ul style="list-style-type: none"> <li>• Heavy-duty die-cast bracket with M18 vertical mounting option</li> <li>• <math>\pm 8^\circ</math> tilt adjustment for cabled sensors</li> <li>• Nuts and lockwasher included</li> </ul>	<p><b>SMB30SC</b></p> <ul style="list-style-type: none"> <li>• Swivel bracket with 30 mm mounting hole for sensor</li> <li>• Black reinforced thermoplastic polyester</li> <li>• Stainless steel mounting and swivel locking hardware included</li> </ul>
 	 

Other Compatible Mounting Brackets (see Banner Photoelectric catalog for more information):

- SMB30MM
- SMB30A
- SMB30FA

# WORLD BEAM® QS30H2O Series Water Sensor

## Accessory Apertures

Opposed-mode QS30 sensors may be fitted with apertures to narrow or shape the sensor's effective beam to more closely match the size or profile of the containers being sensed. A common example is the use of slot type apertures to detect edges of liquid levels.

NOTE: The use of apertures will reduce the excess gain (see attenuation table below).



Aperture model  
APQS30-040V  
shown

Model	Description	
APQS30-040	Circular hole	1 mm (0.04") diameter – 6 each
APQS30-100		2.5 mm (0.10") diameter – 6 each
APQS30-200		5 mm (0.20") diameter – 6 each
APQS30-040H	Horizontal slot	1 x 12 mm (0.04" x 0.47") – 6 each
APQS30-100H		2.5 x 12 mm (0.10" x 0.47") – 6 each
APQS30-200H		5 x 12 mm (0.20" x 0.47") – 6 each
APQS30-040V	Vertical slot	1 x 17 mm (0.04" x 0.67") – 6 each
APQS30-100V		2.5 x 17 mm (0.10" x 0.67") – 6 each
APQS30-200V		5 x 17 mm (0.20" x 0.67") – 6 each
APQS30-DVHX2	Kit containing two of each aperture above – 18 total	
APQS30-DVH	Kit (included with each emitter/receiver) containing one each of aperture models: APQS30-040, APQS30-040H, APQS30-040V	

## Excess Gain Attenuation Factors for QS30E and QS30R Water Sensor Pair

Model	Attenuation Factor	
	Aperture on Both Emitter and Receiver	Aperture on Receiver Only
APQS30-040	5,000	90
APQS30-100	300	20
APQS30-200	20	5
APQS30-040H	60	10
APQS30-100H	13	4
APQS30-200H	4	2
APQS30-040V	60	10
APQS30-100V	13	4
APQS30-200V	4	2

## Examples for Apertures and Water Thickness vs. Excess Gain

The QS30EXH2O / QS30RXH2O sensor pair is used with a horizontal aperture model APQS30-040H on the receiver at 1 meter sensing distance. The excess gain is reduced to approximately 200; 50 mm of water will completely block the signal.

**When the same aperture is used on both the emitter and receiver** at 1 meter, the excess gain is approximately 40; 35 mm of water will block the signal.

NOTE: This example does not include the attenuation from the container holding the water.



**WARRANTY:** Banner Engineering Corp. warrants its products to be free from defects for one year. Banner Engineering Corp. will repair or replace, free of charge, any product of its manufacture found to be defective at the time it is returned to the factory during the warranty period. This warranty does not cover damage or liability for the improper application of Banner products. This warranty is in lieu of any other warranty either expressed or implied.