



# QMT42 Series Fixed-Field Sensors

Sensing Cutoff Point at 500, 750, 1000, 1500, or 2000 mm (20", 30", 39", 59" or 79")



## QMT42 Series Fixed-Field Features

- Fixed-field technology allows direct detection of objects within a defined sensing field, while completely ignoring objects located beyond the sensing field cutoff point
- Compact, rugged, low cost self-contained sensors in metal die-cast housings
- Leakproof IP67 (NEMA 6) construction for reliable sensing in harsh environments
- Outstanding electrical noise immunity
- Dual LED system indicates sensor performance
- Choice of unterminated cable or quick-disconnect connector

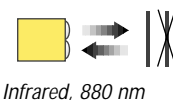

## QMT42 Series Fixed-Field Mode

Models	Range	Cutoff Point	Cable	Supply Voltage	Output Type	Performance Curves
QMT42VN6FF500 QMT42VN6FF500Q	50 mm (2.0") to Cutoff point	500 mm (20")	2 m (6.5') 4-pin Euro QD	10-30V dc	NPN	
QMT42VP6FF500 QMT42VP6FF500Q		500 mm (20")	2 m (6.5') 4-pin Euro QD		PNP	
QMT42VN6FF750 QMT42VN6FF750Q		750 mm (30")	2 m (6.5') 4-pin Euro QD		NPN	
QMT42VP6FF750 QMT42VP6FF750Q		750 mm (30")	2 m (6.5') 4-pin Euro QD		PNP	
QMT42VN6FF1000 QMT42VN6FF1000Q		1000 mm (39")	2 m (6.5') 4-pin Euro QD		NPN	
QMT42VP6FF1000 QMT42VP6FF1000Q		1000 mm (39")	2 m (6.5') 4-pin Euro QD		PNP	
QMT42VN6FF1500 QMT42VN6FF1500Q		1500 mm (59")	2 m (6.5') 4-pin Euro QD		NPN	
QMT42VP6FF1500 QMT42VP6FF1500Q		1500 mm (59")	2 m (6.5') 4-pin Euro QD		PNP	
QMT42VN6FF2000 QMT42VN6FF2000Q		2000 mm (79")	2 m (6.5') 4-pin Euro QD		NPN	
QMT42VP6FF2000 QMT42VP6FF2000Q		2000 mm (79")	2 m (6.5') 4-pin Euro QD		PNP	

# QMT42 Series Fixed-Field Sensors

## Fixed-Field Sensing, Theory of Operation

A fixed-field sensor compares the reflections of its emitted light beam (E) from a target object back to the sensor's two differently-aimed detectors (R1 and R2; see Figure 1). If the near detector (R1) light signal is stronger than the far detector (R2) light signal (object A is closer than the cutoff distance), the sensor responds to the object. If the far detector (R2) light signal is stronger than the near detector (R1) light signal (object B is beyond the cutoff distance), the sensor ignores the object. At the cutoff distance (dashed line), the signals from the two detectors are equal. Objects lying beyond the cutoff distance are ignored, even if they are highly reflective, (see below).

However, it is possible to falsely detect a background object, if it is positioned as shown in Figure 3, or if it moves past the face of the sensor in a direction perpendicular to the sensing axis (and especially if it has a reflective surface; see Figures 2 and 3). To solve this problem, rotate the sensor 90°, as shown in Figure 4.

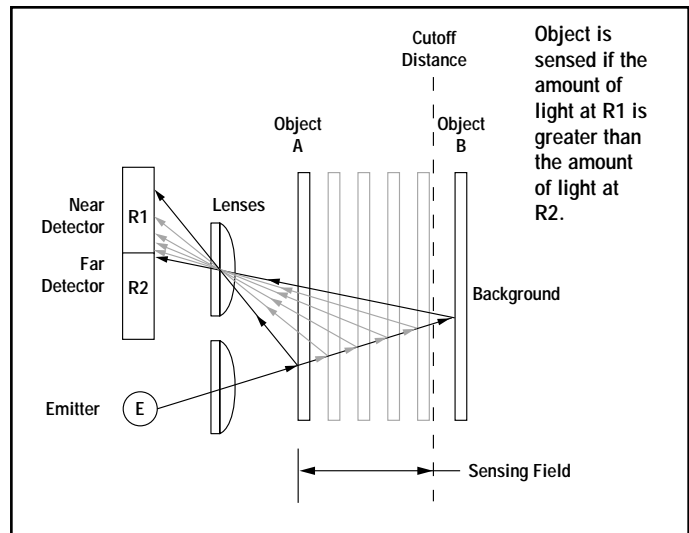

Figure 1. Fixed-field sensing, theory of operation

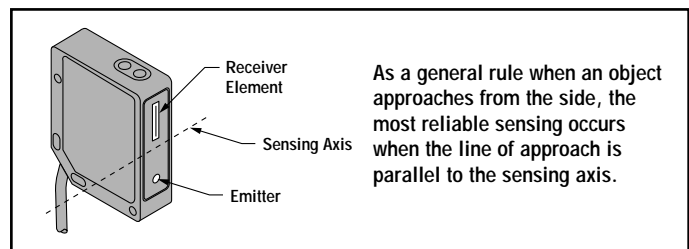

Figure 2. Sensing axis

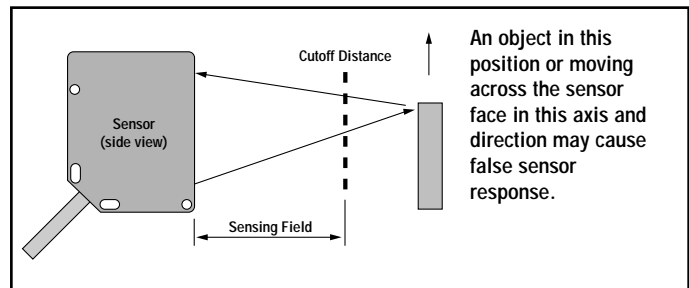

Figure 3. Object beyond cutoff distance (problem)

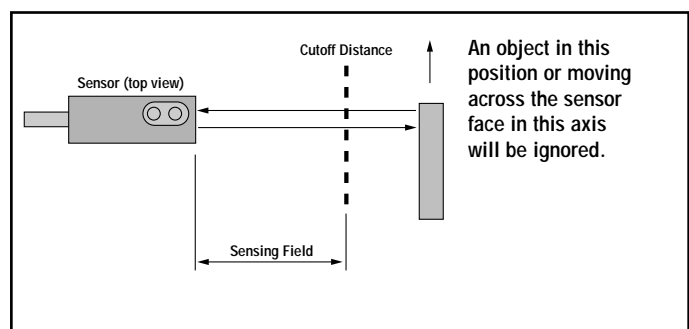

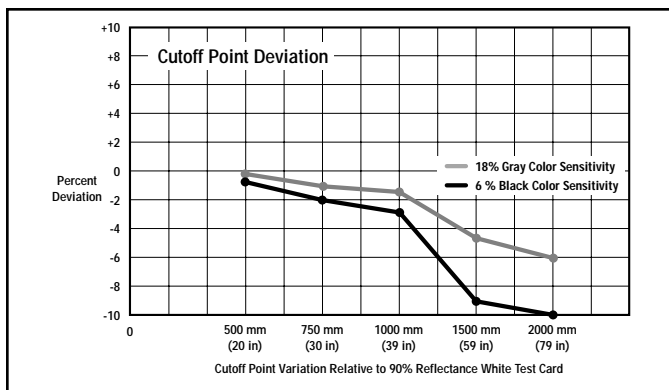

Figure 4. Object beyond cutoff distance (solution)

# QMT42 Series Fixed-Field Sensors

## QMT42 Series Fixed-Field Mode Specification

<b>Sensing Beam</b>	Infrared, 880 nm
<b>Supply Voltage and Current</b>	10 to 30V dc (10% maximum ripple) at less than 40 milliamps
<b>Supply Protection Circuitry</b>	Protected against reverse polarity and transient voltages
<b>Output Configuration</b>	SPDT (complementary) solid-state dc switch; choose NPN (current sinking) or PNP (current sourcing) models. <b>Light operate:</b> N.O. output conducts when the sensor sees its own modulated light <b>Dark operate:</b> N.C. output conducts when the sensor sees dark
<b>Output Rating</b>	100 mA maximum (each output) <b>OFF-state leakage current:</b> < 5 microamps at 30V dc <b>ON-state saturation voltage:</b> < 1V at 10 mA dc; < 1.5V at 100 mA dc
<b>Output Protection Circuitry</b>	Protected against false pulse on power-up and continuous overload or short-circuit of outputs Overload trip point $\geq$ 150mA, typical, at 20°C
<b>Output Response Time</b>	1 millisecond on and off NOTE: 100 millisecond delay on power-up; outputs are non-conducting during this time
<b>Repeatability of Response</b>	250 microseconds
<b>Sensing Hysteresis</b>	Less than 5% of cutoff distance - 2000 mm models Less than 4% of cutoff distance - 1500 mm models Less than 3% of cutoff distance - 1000 mm models Less than 2% of cutoff distance - 750 mm models Less than 1% of cutoff distance - 500 mm models
<b>Cutoff Point Tolerance</b>	$\pm$ 10% of nominal cutoff distance
<b>Indicators</b>	Two LEDs: Green and Yellow GREEN <b>glowing steadily</b> = power to sensor is ON GREEN <b>flashing</b> = output is overloaded YELLOW <b>glowing steadily</b> = light is sensed; normally open output ON YELLOW <b>flashing</b> = marginal excess gain (1-1.5x) in light condition
<b>Construction</b>	Housings are die-cast zinc alloy with black acrylic polyurethane finish; lenses are acrylic
<b>Environmental Rating</b>	IP67; NEMA 6
<b>Connections</b>	2 m (6.5') or 9 m (30') attached cable, or 4-pin Euro-style quick-disconnect fitting; cables for QD models are purchased separately
<b>Operating Conditions</b>	<b>Temperature:</b> -20° to +55°C (-4° to 131°F) <b>Maximum relative humidity:</b> 90% at 50°C (non-condensing)
<b>Certifications</b>	



### Interpretation of Cutoff Point Deviation Curve

The percentage of deviation indicates a change in the cutoff point for either 18% gray or 6% black targets, relative to the cutoff point for a 90% reflective white test card.

As an example, the cutoff point decreases 10% for a 6% reflectance black target when the cutoff point is 2000 millimeters (79") using a 90% reflective white test card. In other words, the cutoff point for the black target is 1800 millimeters (71").

# QMT42 Series Fixed-Field Sensors

## QMT42 Series Dimensions

### Cabled Models

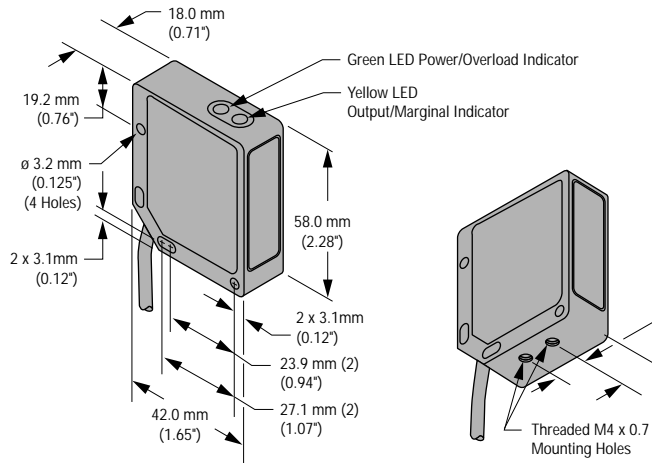

### Quick-Disconnect models

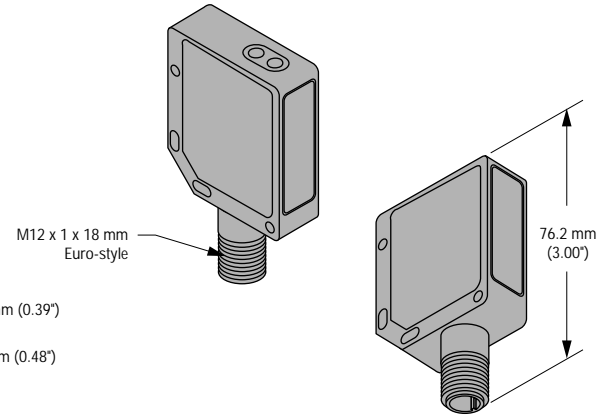

## QMT42 Series Hookup Diagrams

### Sensors with NPN (Sinking) Outputs

#### Cabled Models

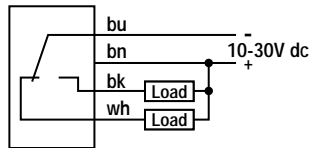

#### Quick-Disconnect Models

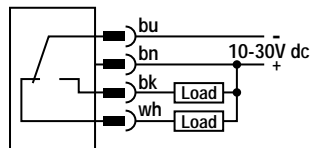

### Sensors with PNP (Sourcing) Outputs

#### Cabled Models

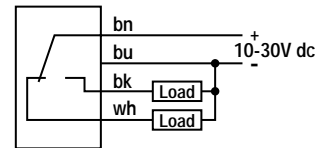

#### Quick-Disconnect Models

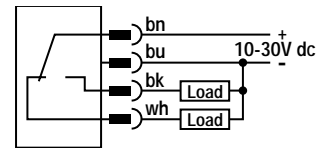

## Accessories

### Quick-Disconnect (QD) Cables

Style	Model	Length	Dimensions	Pinout
4-pin Euro-style straight	MQDC-406 MQDC-415 MQDC-430	2 m (6.5') 5 m (15') 9 m (30')		
4-pin Euro-style right-angle	MQDC-406RA MQDC-415RA MQDC-430RA	2 m (6.5') 5 m (15') 9 m (30')		

# QMT42 Series Fixed-Field Sensors

## QMT42FF Series Mounting Brackets

SMB42T	<ul style="list-style-type: none"> <li>• Right-angle mounting bracket, stainless steel</li> <li>• M3 hardware included</li> </ul>	SMB42L	<ul style="list-style-type: none"> <li>• 13 gauge stainless steel</li> <li>• Hardware included</li> </ul>

# QMT42 Series Fixed-Field Sensors

---



**WARRANTY:** Banner Engineering Corp. warrants its products to be free from defects for one year. Banner Engineering Corp. will repair or replace, free of charge, any product of its manufacture found to be defective at the time it is returned to the factory during the warranty period. This warranty does not cover damage or liability for the improper application of Banner products. This warranty is in lieu of any other warranty either expressed or implied.



**WARNING . . . Not To Be Used for Personnel Protection**

Never use these products as sensing devices for personnel protection. Doing so could lead to serious injury or death.

These sensors do NOT include the self-checking redundant circuitry necessary to allow their use in personnel safety applications. A sensor failure or malfunction can cause either an energized or de-energized sensor output condition. Consult your current Banner Safety Products catalog for safety products which meet OSHA, ANSI and IEC standards for personnel protection.